

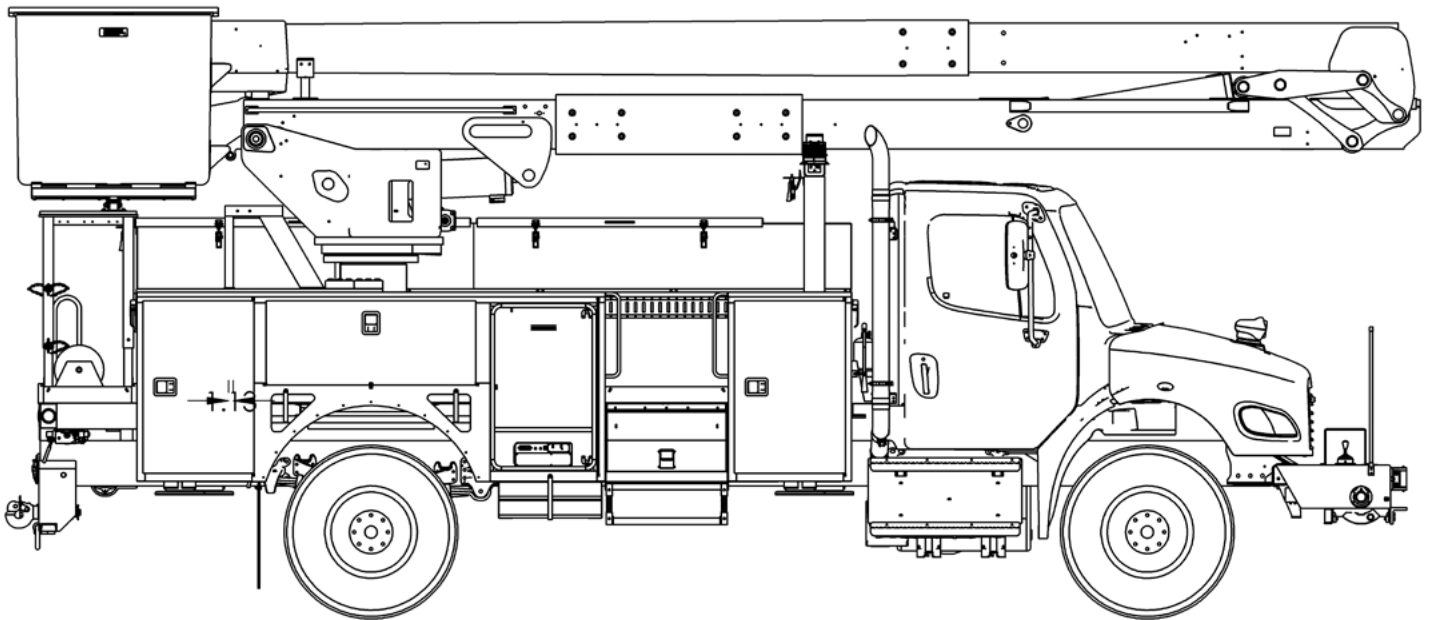

TECH TIPS

AC DIELECTRIC TESTING OF CATEGORY A AERIAL DEVICES

NO. 95



SERVICE CALL:
AC DIELECTRIC TESTING OF
CATEGORY A AERIAL DEVICE



MODEL(S):
RM-75



TOOLS NEEDED:
AC DIELECTRIC TESTER
INSULATING OUTRIGGER PADS
MULTIMETER CAPABLE OF
MEASURING RESISTANCE (OHMS)
SAFETY EQUIPMENT TO CREATE
A DIELECTRIC TEST AREA

TEREX UTILITIES TECHNICAL SUPPORT TEAM

PHONE: 1-844-TEREX4U (1-844-837-3948) | EMAIL: UTILITIES.SERVICE@TEREX.COM



DANGER

Failure to obey the instructions and safety rules in the appropriate Operator's Manual and Service Manual for your machine will result in death or serious injury.

Many of the hazards identified in the Operator's Manual are also safety hazards when maintenance and repair procedures are performed.

DO NOT PERFORM MAINTENANCE UNLESS:

- ✓ You are trained and qualified to perform maintenance on this machine.
- ✓ You read, understand and obey:
 - manufacturer's instructions and safety rules
 - employer's safety rules and worksite regulations
 - applicable governmental regulations
- ✓ You have the appropriate tools, lifting equipment and a suitable workshop.

The information contained in this Tech Tip is a supplement to the Service Manual. Consult the appropriate Service Manual of your machine for safety rules and hazards.



TECH TIP 95 | RELEASED 04.18.2023 | VERSION 1.0
©TEREX UTILITIES. ALL RIGHTS RESERVED

CONTENTS

TECH TIP#95

4 | *Set-up*
STEP 1 - STEP 3

6 | *Inspect and test the lower test electrode system*
STEP 4

7 | *Inspect conductive shield and gradient control device*
STEP 5 - STEP 6

8 | *Install boom tip bonding cables*
STEP 7

9 | *Install jumpers*
STEP 8 - STEP 9

11 | *Attach the current meter*
STEP 10 - STEP 11

12 | *Plug in and turn on the dielectric tester*
STEP 12

13 | *Testing the lower boom*
STEP 13 - STEP 16

14 | **STEP 17 - STEP 18**

15 | *Testing upper control handle*
STEP 19 - STEP 20

STEP 1

In the interest of safety, the dielectric testing area should be separated from the normal work area by means of a barrier to keep anyone unassociated with the procedure out of the testing area. If a barrier is not available, use a spotter(s). The AC Dielectric Tester voltage source should also be contained within this area.

The test area must be free of any obstructions both on the ground and above/around the unit. The boom must not be near any trees, buildings or energized power lines when elevated for testing.



Verify that the boom is designed as insulated before proceeding with the dielectric test.

STEP 2

Consult the ID Placard to determine whether the unit is insulated or non-insulated. If the unit is insulated, the qualification voltage and rating of the unit will be shown. **Figure 1 and 2**

Units which have been tested and rerated at higher than 69KV will have a rerate tag alongside the ID plate showing the new rating.

STEP 3

Complete a thorough daily inspection of the unit, including running all boom functions through their full range of motion before beginning any dielectric testing. Daily inspection criteria can be found in the unit specific operators and maintenance manuals.

The fiberglass booms must be clean, dry and in good physical condition. Check carefully for any bird's nests, material buildup, or hydraulic leaks in the boom or control areas. Check under the boom tip covers and look down each boom from both ends checking for a blockage or any signs of a leak. A bird's nest, blockage, or leak in the boom could ignite and cause a fire during the dielectric test.

If a blockage or leak is found it must be repaired and the unit cleaned prior to continuing with the dielectric test.

Record all unit info and weather conditions on the dielectric test sheet prior to starting the test. The test sheets are included in the unit specific manual and can be copied as needed.

Insulated
Non-Insulated

Qualification
Voltage

Insulating
Category

NAME & MODEL		YEAR	UNIT EQUIPPED WITH <input type="checkbox"/> PLATFORM(S)	
SER. NO.			LBS. PER PLATFORM	
RATED PLATFORM HEIGHT			TOTAL LBS. ALL PLATFORMS	
THIS DEVICE COMPLIES WITH REQUIREMENTS OF:		(See Load Charts for capacity)	EQUIPPED WITH MATERIAL HANDLING ATTACHMENT: YES <input type="checkbox"/> NO <input type="checkbox"/>	
ANSI <input type="checkbox"/>			BOOM TIP <input type="checkbox"/>	
NON-INSULATED <input type="checkbox"/>		DESIGN VOLTAGE	INSULATING CATEGORY	
INSULATED <input type="checkbox"/>		QUALIFICATION VOLTAGE	DATE OF TEST	
CAPACITY RATING				
SEE LOAD CHART PLATE(S) FOR SPECIFIC CONFIGURATION CAPACITIES. UNIT MUST BE OPERATED ON A FIRM AND LEVEL SURFACE WITH THE OUTRIGGERS, WHEN SO EQUIPPED. EXTENDED DOWN TO A SOLID FOOTING. USE OUTRIGGER PADS.				
MAXIMUM PRESSURE (PSI)		CYLINDER	PART NUMBER	PART NUMBER
HYDRAULIC SYSTEM		OUTRIGGERS		
HYDRAULIC WINCH		OUTRIGGERS		
PNEUMATIC SYSTEM		BOOM LIFT		
CONTROL SYSTEM VOLTAGE		EXTENSION		
		ELBOW		
		LOWER LIFT BOOM		
		HYDRAULIC LIFT		
OPERATION				
WARNING: BEFORE OPERATING UNIT, READ AND UNDERSTAND ALL OPERATING AND SAFETY INFORMATION IN MANUAL AND ALL INFORMATION ON THIS PLACARD.				
General Instructions:				
1. Lubricate unit per lubrication chart.				
2. Check unit for visible defects or loose objects.				
3. Check insulated boom and other insulating material for cleanliness.				
4. Check all decals for legibility. Replace if necessary.				
5. Start engine or engage power take off (PTO).				
6. Set vehicle park brake securely before operation.				
7. Extend all hydraulic outriggers to a solid footing.				
8. Operate all hydraulic controls slowly and deliberately for smooth platform function.				
9. Minimum ambient temperature for operation <input type="text"/> °F. Maximum <input type="text"/> °F. (See Manual)				
ATTENTION				
1. Do not alter components without written approval from the manufacturer. All updates in effect, (both the manufacturer as well as ANSI/OSHA) at the time of rebuild should be performed.				
2. If unit is remounted by entity other than a Terex Telelect approved distributor, Terex Telelect must be contacted to insure that mounting is completed to specifications.				
3. If unit is resold, Terex Telelect must be notified in writing, within 60 days, of new owner and what steps were taken to instruct the new owner as to the operation and maintenance of the unit. Copies of Terex Telelect operators and maintenance manuals must accompany the unit at the time of sale.				
Copies of maintenance and inspection records must accompany unit at the time of sale. All updates by Terex Utilities must be completed at the time of sale.				
THIS UNIT WAS INSTALLED BY: <input type="text"/>				
DATE OF COMPLETED UNIT TESTS: <input type="text"/>				
		500 Oakwood Road PO Box 1150 Watertown, South Dakota 57201 USA		

FIGURE 1

Insulating
Category

Qualification
Voltage

REVISED ELECTRICAL RATING INFORMATION	
<input type="text"/>	MODEL
<input type="text"/>	SERIAL NUMBER
The Original ID Plate applies except for Insulation Rating. The Electrical Rating ONLY complies with:	
ANSI <input type="text"/>	INSULATING CATEGORY <input type="text"/>
NON-INSULATED <input type="checkbox"/>	DATE OF TEST <input type="text"/>
INSULATED <input type="checkbox"/>	QUALIFICATION VOLTAGE <input type="text"/>
Terex South Dakota 500 Oakwood Road PO Box 1150 Watertown, South Dakota 57201 USA	
439225B	

FIGURE 2

STEP 4

Inspect and test the Lower Test Electrode System.

This is done by checking for “Electrical Continuity” between the center core of the Amphenol connector on the boom and the locations listed below. There should be less than 100 OHMS of resistance shown on the meter. It will typically be less than 5 OHMS.

- Outer Test Band
- Inner Test Band
- Hose Assembly Bulkhead
- PVC Tube Bands
- Leveling Rod Bands



Testing for “Electrical Insulation” between the center core of the Amphenol connector on the boom and steel elbow will also need to be completed. There should be more than 10,000 OHMS of resistance shown on the meter. It will typically be over 1 MOHM.

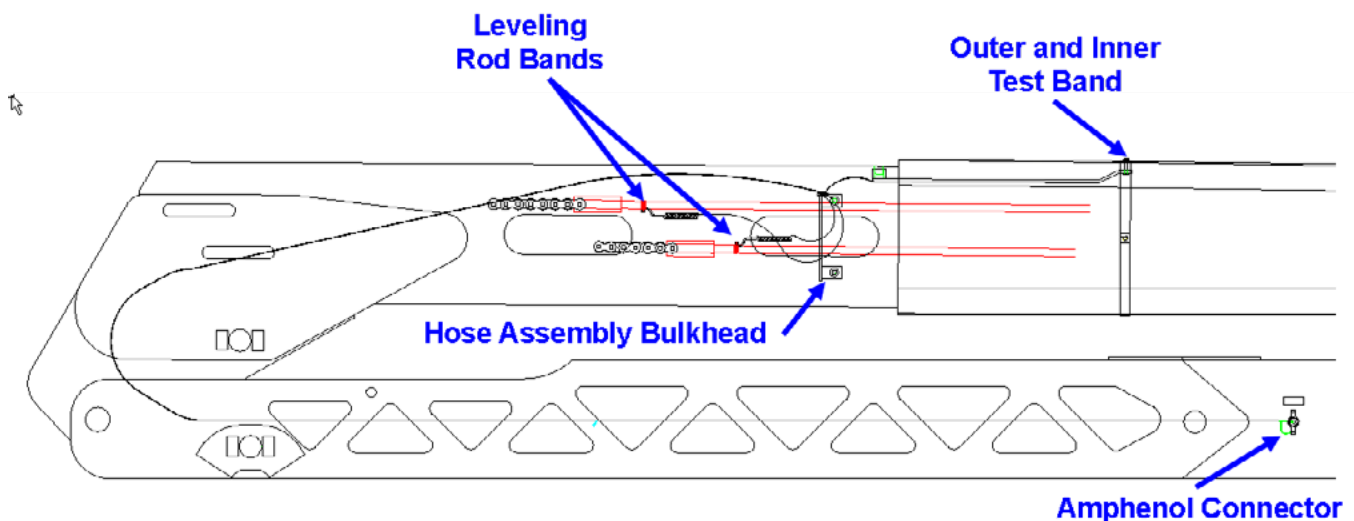

STEP 5

Inspect the Conductive Shield for the Test Band.

First check for “Electrical Continuity” between the Conductive Shield and the steel boom. There should be less than 100 Ω of resistance shown on the meter. It will typically be less than 5 Ω .

Next check for “Electrical Insulation” between the Test Band and the Conductive Shield. There should be more than 10,000 Ω of resistance shown on the meter. It will typically be over 1 M Ω .



STEP 6

Inspect the Gradient Control Device.

Check for “Electrical Continuity” between the Gradient Control Device and the metal at the boom tip. There should be less than 100 Ω of resistance shown on the meter. It will typically be less than 5 Ω .



STEP 7

Inspect the Boom Tip Bonding cables.

Inspect all boom tip bonding cables as shown in the figure below for proper connection. There should be less than 100 Ω of resistance shown on the meter between any two points of connection.

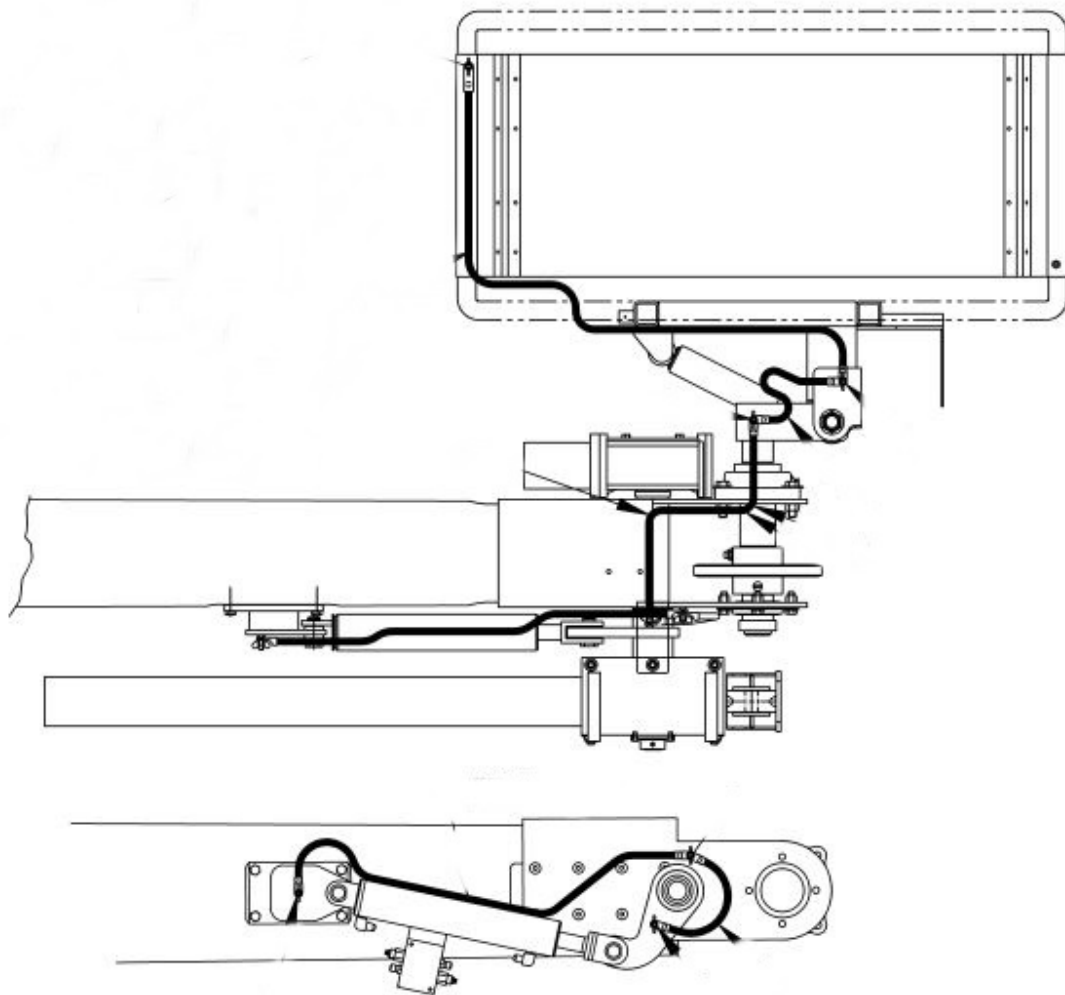

STEP 8

Drive the unit into the dielectric testing area and onto the insulating platforms (pads) centered under the tires. Engage the park brake, place the transmission in neutral and turn on the PTO.

Set the unit up for operation by deploying the outriggers onto insulating platforms (pads) centered under the outrigger foot, reference Figure 8. Once outrigger setup is complete, shift the outrigger/unit selector into the unit position.

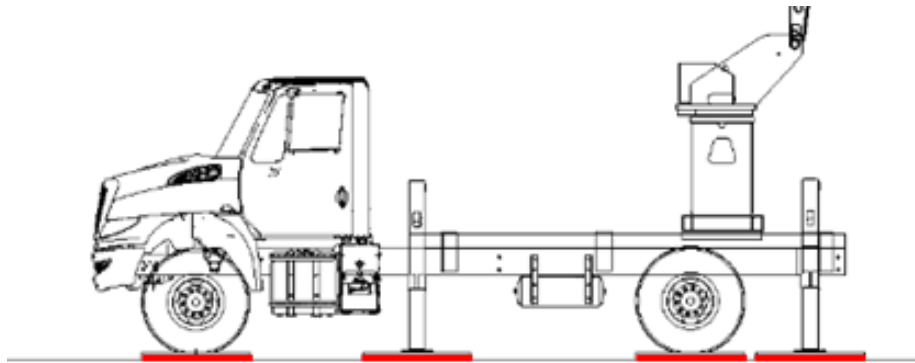

FIGURE 8

STEP 9

To begin setup for testing the upper boom, install jumpers between components in the following locations as shown in Figure 9:

- Turntable above rotation to pedestal below rotation (#1)
- Turntable above rotation to lower boom (#2)
- Lower boom insert (#3)
- Upper boom to Lower Boom (#4)
- Platform bracket to boom tip bracket (#5)
- Jib bracket (if equipped) to platform bracket
- Truck chassis to earth ground (#6)

Verify that the jumpers make good contact by removing paint, if needed, at the attachment location prior to attaching the jumpers. Some units are equipped with stainless bolts specifically for dielectric testing, use these if equipped. For the truck chassis to earth ground use the ground lug or loop if available at the rear of the truck.

STEP 9 (Continued)

The jumpers and connections are shown in RED in the following Figures. They do not reflect the actual connection points where the jumpers are installed on the unit but are only a reference to the general location.

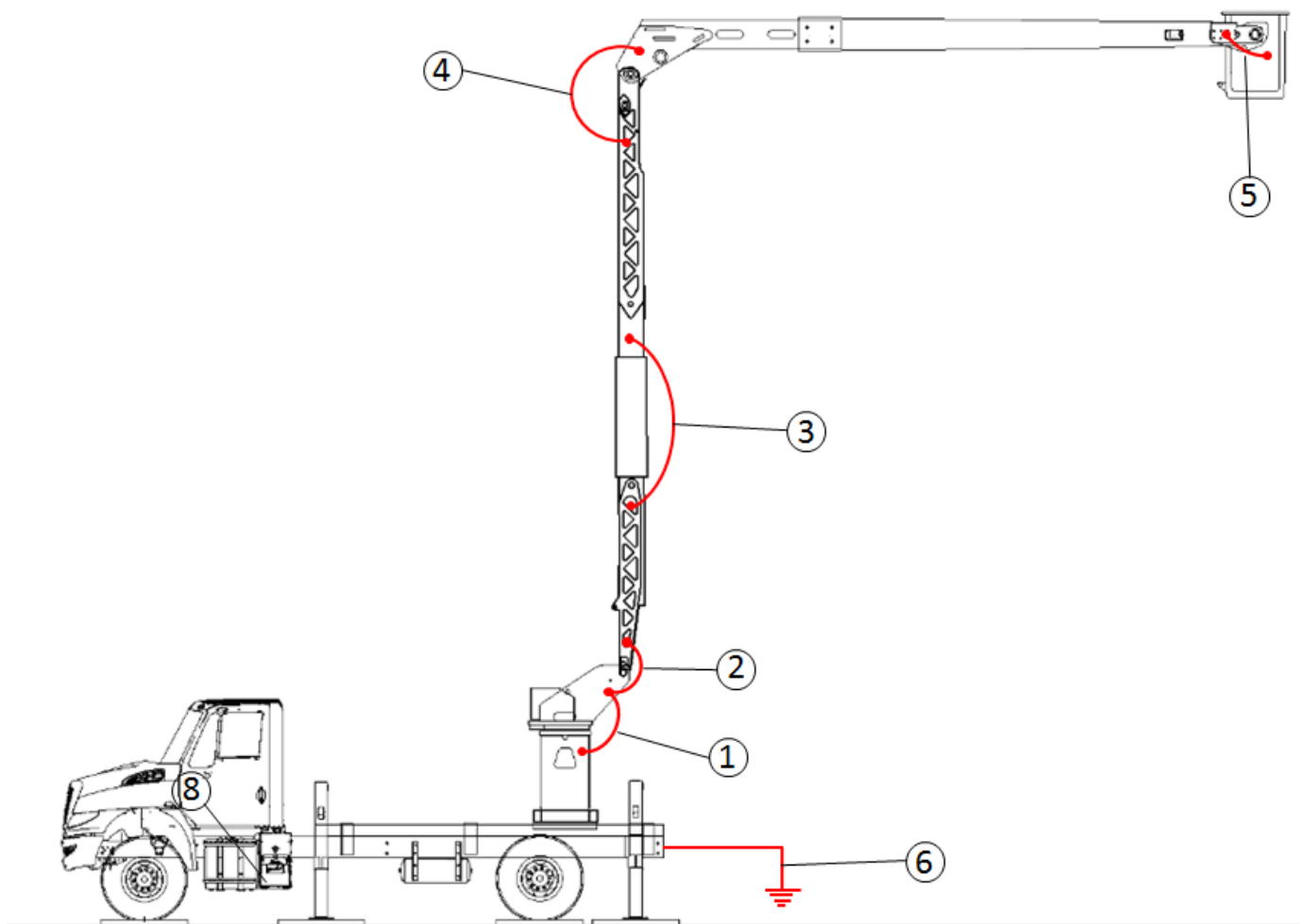

FIGURE 9

STEP 10

Attach the current meter return to the Amphenol connector shown in Step 4. The connector is located on the lower boom just forward of the lower boom insert.

Attach the voltage source from the AC Dielectric Tester to the boom tip. This may be attached at the same location as the jumpers that were installed at the boom tip. See Figure 10. Keep the test machine directly below or away from the truck if possible.

Follow the instructions of the dielectric testing machine for any further connections that are required. Verify that the dielectric tester has been grounded.

STEP 11

Position the lower boom at 90 degrees and upper booms at 0 degrees

Visually check that all jumpers, voltage source from the AC Dielectric Tester, and Current Meter Return at the Amphenol Connector are still connected once unit is in position. See Figure 10.



The dielectric tester controls should be located outside the dielectric test area.

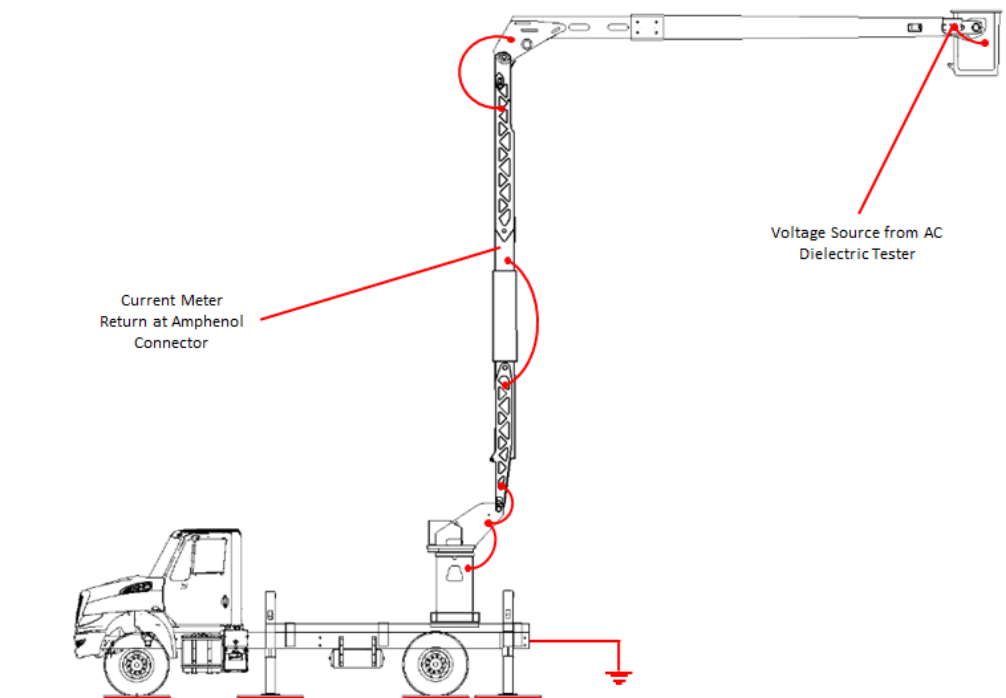

FIGURE 10

STEP 12

Plug in and turn on the dielectric tester. Raise the voltage control to the required voltage listed on the test sheet. Monitor the volt and current meters to verify the test is working correctly. If the current meter reads zero, verify all connections.

If the current meter value stays below the Max Leakage, continue the test until complete, record readings, return the voltage control to 0, turn off and unplug the dielectric machine.

If the current meter value exceeds the Max Leakage at any point during the test, return the voltage control to 0, turn off and unplug the dielectric machine. Begin troubleshooting to determine why the boom will not pass the dielectric test. Reference **Tech Tip #51** for further troubleshooting help.

The upper boom Qualification and Periodic readings are shown below. Qualification testing is done on a new unit install or after a major component such as a boom is replaced. Periodic testing is done once a year to verify dielectric integrity of the unit.

For a 69kv Category AAC Qualification test, the reading for Rated Voltage should be no higher than 40 μA for 1 minutes at 40 kV and Double Rated should be no higher than 80 μA for 1 minutes at 80 kV.

UNIT QUALIFICATION	TEST TIME	1 MINUTE AC TEST VOLTAGE	
		Rated	Double Rated
VOLTAGE AC	AM PM	40 kv	80 kv
69kv	Start	μA	μA
	Finish	μA	μA
S/N	Max Leakage	40 μA	80 μA

The 10 second Momentary Withstand Voltage Test should be no higher than 120 μA for 10 Seconds at 120 kV.

UNIT QUALIFICATION	10 Sec. Momentary Withstand Voltage Test (No Flashover Allowed)
VOLTAGE AC	120 kv
69kv	μA
	μA
S/N	120 μA

For a 69kv Category AAC Periodic/Maintenance Test the reading should be no higher than 60 μA for 1 minute at 60 KV.

69KV	60KV	Start	μA
		Finish	μA
		Max. Leakage	60 μA

μA =Microamp

STEP 13

Once testing is complete bring the upper and lower booms down to access the jumpers, voltage source and Current Meter Return at the Amphenol connector. Disconnect the voltage source and Current Meter Return at the Amphenol connector from the boom.

STEP 14

- Remove the following jumpers:
- Turntable above rotation to pedestal below rotation (#1)
- Lower boom insert (#3)
- Upper boom to lower boom (#4)
- Platform bracket to boom tip bracket (#5)
- Jib bracket (if equipped) to platform bracket
- Truck chassis to earth ground (#8)

See **Figure 9** to identify jumpers.

STEP 15

To begin setup for testing the lower boom, raise the upper boom up to a 45-degree angle. Raise the lower boom high enough to clear all obstacles and rotate the turntable 180 degrees so that the knuckle is off the back of the unit as shown in **Figure 14**.

STEP 16

Attach the Current Meter Return to the back of the truck as shown in **Figure 14**. If a ground lug or loop is available, attach the return there.

STEP 17

Attach the voltage source from the AC Dielectric Tester to the knuckle side of the lower boom and install jumpers between components in the following locations as shown in Figure 14 below:

- Turntable above rotation to pedestal below rotation (#1)

Visually check that all jumpers, voltage source from the dielectric tester and the Current Meter Return are still connected once the unit is in position.

STEP 18

Plug in and turn on the dielectric tester. Raise the voltage control to the required voltage listed on the test sheet. Monitor the volt and current meters to verify that the test is working correctly.

If the current meter value stays below the Max Leakage continue test until complete, record readings, return the voltage control to 0, turn off and unplug the dielectric machine.

If the current meter value exceeds the Max Leakage at any point during the test return the voltage control to 0, turn off and unplug the dielectric machine. Begin troubleshooting to determine why the boom will not pass the dielectric test. Reference **Tech Tip #51** for further troubleshooting help.

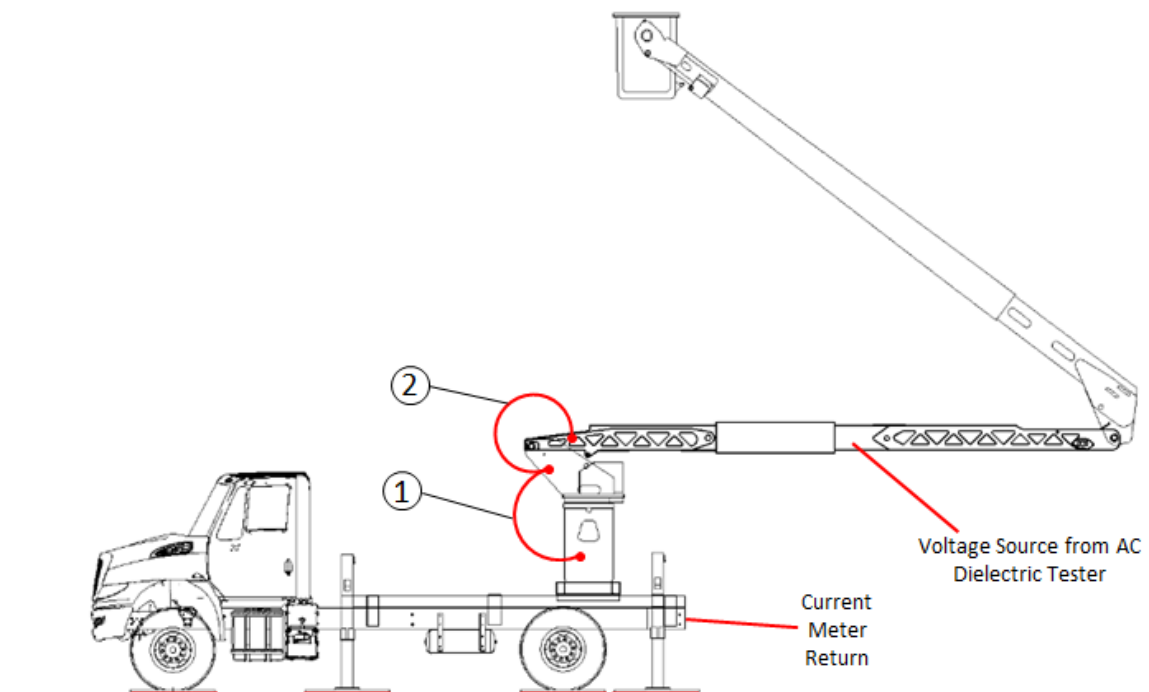

FIGURE 14

STEP 18 (Continued)

The lower boom Qualification and Periodic readings are shown below.

For a Chassis Insulating System (Lower Boom Insert) Qualification test, the reading should be no higher than 3000 μA for 3 minutes at 50 kV.

			TEST TIME	3 MINUTE AC TEST VOLTAGE
			AM PM	50 kv
			Start	μA
			Finish	μA
S/N			Max Leakage	3000 μA

For a Chassis Insulating System (Lower Boom Insert) Periodic/Maintenance test the reading should be no higher than 3000 μA for 1 minute at 35 kV.

AC TEST - 1 Minute		
TEST VOLTAGE	Time	Leakage
35 KV	Start	μA
	Finish	μA
	Max. Leakage	3000 μA

μA =Microamp

STEP 19

Once testing is complete disconnect the voltage source from the boom.

Remove all the jumpers from the following locations indicated in **Figure 14**:

- Turntable above rotation to pedestal below rotation (#1)
- Turntable above rotation to lower boom (#2)

Remove the Current Meter Return from the back of the truck.

STEP 20

To begin setup for testing the upper control handle, bring the platform to the ground mount position at the back of the truck.

STEP 21

Remove the control head cap cover to expose the bonding cable. Remove the bonding cable that connects the control head cap to the control head base as shown below in red.

Reinstall the control head cap cover. **Figure 17**

STEP 22

Attach the voltage source from the AC Dielectric Tester to the control handle using a spring with the cable going over the top of the platform as shown below. **Figure 18**

If equipped with a metal platform liner, remove the liner before testing.

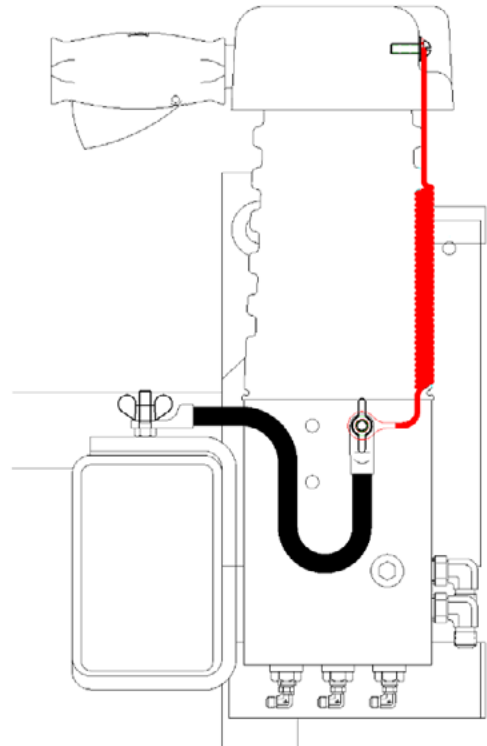

FIGURE 17



FIGURE 18

STEP 23

Reach under the upper control cover and attach the current meter return to a fitting that is attached to the upper control valve as shown below. (Cover removed for clarity)



STEP 24

Elevate the platform to at least 4 feet above the ground. Visually check that all jumpers, the voltage source from the dielectric tester, and the return are still connected once the unit is in position.

STEP 25

Plug in and turn on the dielectric tester. Raise the voltage control to the required voltage listed on the test sheet. Monitor the volt and current meters to verify that the test is working correctly.

If the current meter value stays below the Max Leakage continue the test until it is complete, record readings, return the voltage control to 0, turn off and unplug the dielectric machine.

If the current meter value exceeds the Max Leakage at any point during the test, return the voltage control to 0, turn off and unplug the dielectric machine. Begin troubleshooting to determine why the single stick control handle will not pass the dielectric test.

The Single Stick Qualification and Periodic readings are shown below.

For a Single Stick Control AC Qualification and Periodic/ Maintenance test the reading should be no higher than 400 μA for 3 minutes at 40 kV.

Test time: AM / PM 3 minutes		AC test (40KVAC)	Leakage
Start			μA
Finish			μA
		Allowable	400 μA

μA =Microamp

STEP 26

Once testing is complete lower the platform to the ground mount position. Remove the spring from the control handle and current meter return from the upper control valve fitting. Reinstall the bonding cable between control head cap to the control head base.

STEP 27

Store the unit and raise the outriggers. Remove any barriers around the unit and drive the unit off the pads and out of the dielectric test area.



FOR FURTHER ASSISTANCE,
CONTACT THE TEREX UTILITIES TECHNICAL SUPPORT TEAM
PHONE: **1-844-TEREX4U (1-844-837-3948)** | EMAIL: **UTILITIES.SERVICE@TEREX.COM**
