

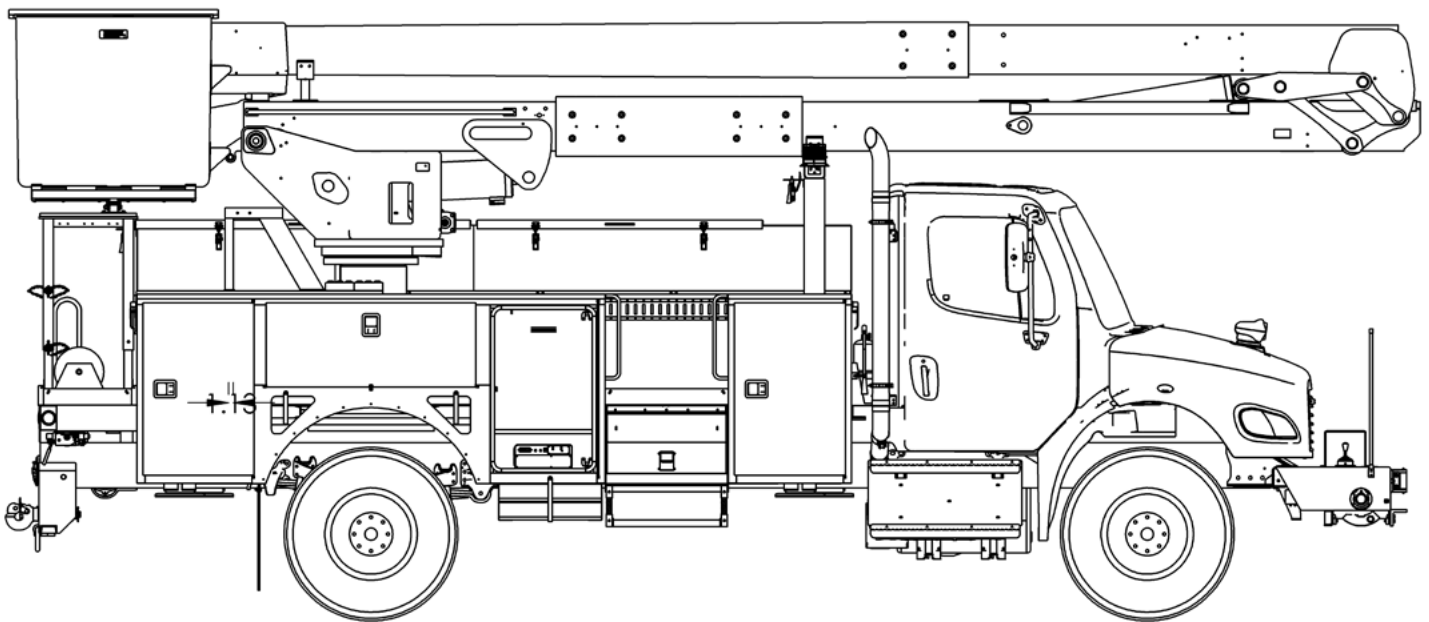

# TECH TIPS

INSPECTING LEVELING CHAINS ON UNITS WITH STANDARD CHAINS

NO. 58



**SERVICE CALL:**  
INSPECTING LEVELING CHAINS  
ON UNITS WITH STANDARD  
CHAINS



**MODEL(S):**  
HR, HRX, TC, TCX, SC, SCM, XT,  
RM, AND RMX



**TOOLS NEEDED:**  
PETROLEUM BASE SOLVENT  
30W NON-DETERGENT OIL  
MEASURING DEVICE

TEREX UTILITIES TECHNICAL SUPPORT TEAM

PHONE: 1-844-TEREX4U (1-844-837-3948) | EMAIL: [UTILITIES.SERVICE@TEREX.COM](mailto:UTILITIES.SERVICE@TEREX.COM)



## **DANGER**

Failure to obey the instructions and safety rules in the appropriate Operator's Manual and Service Manual for your machine will result in death or serious injury.

Many of the hazards identified in the Operator's Manual are also safety hazards when maintenance and repair procedures are performed.

## **DO NOT PERFORM MAINTENANCE UNLESS:**

- ✓ You are trained and qualified to perform maintenance on this machine.
- ✓ You read, understand and obey:
  - manufacturer's instructions and safety rules
  - employer's safety rules and worksite regulations
  - applicable governmental regulations
- ✓ You have the appropriate tools, lifting equipment and a suitable workshop.

The information contained in this Tech Tip is a supplement to the Service Manual. Consult the appropriate Service Manual of your machine for safety rules and hazards.



TECH TIP 58 | RELEASED 07.28.2022 | VERSION 1.0  
©TEREX UTILITIES. ALL RIGHTS RESERVED

# CONTENTS

## TECH TIP#58

### TOC

4

| *Leveling chain inspections*

**INTRODUCTION**  
**STEP 1**

6

| *Daily Inspection*

| *5 Yearr Inspection*

**STEP 2 - STEP 3**

7

| *Remove the chains*

**STEP 4**

8

| *Clean the chain*

| *Inspect*

| *Measure*

**STEP 5 - STEP 7**

10

| *Compare to maximum allowable elongaation*

**STEP 8**

11

| *Replace or reinstall chain as necessary*

**STEP 9 - STEP 10**

12

| *Operate unit*

**STEP 11**

## INTRODUCTION

This tech tip is for units equipped with standard leveling chains. Please reference the kit sheet for the specific unit to determine which chains are installed.

Note: If there is a question about the type of chain installed on the unit by contacting the Terex Utilities Technical Support team at 1-844-Terex4U (1-844-837-3948) or emailing them at [utilities.service@terex.com](mailto:utilities.service@terex.com).

All Optima and XT Pro models are built with the extended life leveling chains. These chains require replacement after 10 years, there is not a requirement to remove and measure at 5 years. The inspection may require a light and mirror to accomplish properly.

All chains require lubrication at 90-day intervals.



The XT series may have standard or extended life leveling chains depending on the age and configuration. The XT Pro series only have extended life 10 year leveling chains. Consult the unit specific manual and ID Placard to determine whether the machine is an XT or an XT Pro.

---

## STEP 1

Leveling chains need to be visually inspected daily. The inspection intervals shown below are for reference only, refer to the unit specific maintenance manual for the correct inspection intervals.

### Figure 1

## FREQUENT AND PERIODIC INSPECTION INTERVALS

### DAILY

1. Check all controls and interlock for proper operation.
2. Inspect fall arrest equipment and attachments.
3. Inspect visual and audible devices.
4. Check cleanliness and dryness of fiberglass components.
5. Visually check for missing, damaged, or loose covers and guards.
6. Check for missing and illegible warning, operational, or instructional markings.
7. Visually check oil level in hydraulic reservoir.
8. Visually inspect for leaks in hydraulic system and hose condition.
9. Visually check all cylinders for leaks.
10. Visually inspect leveling system. (Chains and Insulator Assemblies)
11. Visually inspect all pins, retainers, and fasteners for tightness.
12. Visual inspection of all structural members for cracks and permanent deformation.
13. Check for rotational obstructions.
14. Visual inspection of all visible electrical wires.
15. Operational test of all boom functions and drift.
16. Inspect load line, hook, and slings.
17. Tires for damage and proper inflation.
18. Parking brake for proper operation.
19. Vehicle inspection and load securement.
20. If equipped, verify lower boom angle indicator is "ON" when lower boom angle is in **Zone B** angle designated on jib capacity load chart. Check when truck and turntable are level to ground.

### 90 DAYS (360 HOURS)

1. Check tension on leveling system.
2. Visually inspect all sprockets, chains, pulleys, and pins.
3. Lubricate all points per lubrication chart recommendations.
4. Apply lubricant to rotation gearbox pinion and turntable bearing.
5. Repair or replace items found to be worn or damaged.
6. Replace return filter (first 90 days or 90 days after major hydraulic component replacement).
7. Replace hi-pressure filter. Closed Center units only (first 90 days or after major hydraulic component replacement).
8. Verify interlock and enable operation.
9. Daily inspections.

### 180 DAYS (720 HOURS)

1. Inspect exposed hoses.
2. Clean hydraulic tank breather.
3. Check tightness of rotation bearing bolts, turntable to bearing, pedestal to base plate, and bearing to pedestal for proper torque.
4. Daily and 90 days (360 hours) inspections.

FIGURE 1

## STEP 2 - Daily Inspection

Visually inspect the chain for any cracks, turned pins, or damage to the chain or links. If any damage or deformities are found, the chain must be replaced. If the chain is rusty or does not move freely it must be replaced.

**Note:** If any of the pin stamps appear to be turned on any chain, new or one in service, replace the chain immediately.

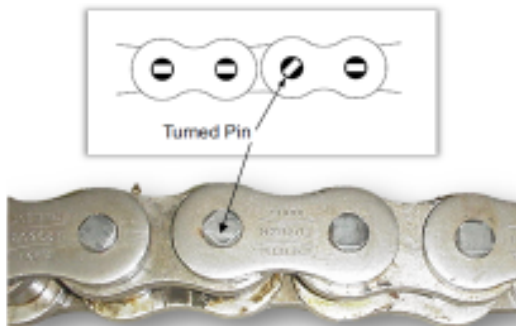

**FIGURE 2 - Turned Pin**

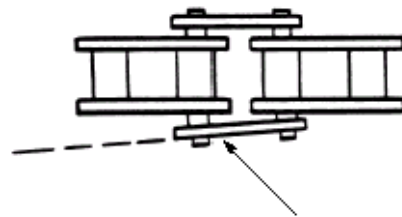

**FIGURE 3 - Link Plate Distortion**

## STEP 3 - 5 Year Inspection

The Terex standard leveling chains are required to be removed, inspected, and measured at 5-year intervals.

Consult your unit specific maintenance manual to determine the required interval and allowable wear limits for your unit.

## Lubrication

The proper lubricant for chains is 30w non-detergent oil. Spray cans are available as part #471317 or use a container of 30w non-detergent oil and a brush to lubricate all rollers and pins.

## STEP 4

Remove the chains according to the instructions in the unit specific maintenance manual. The example below is for reference only.

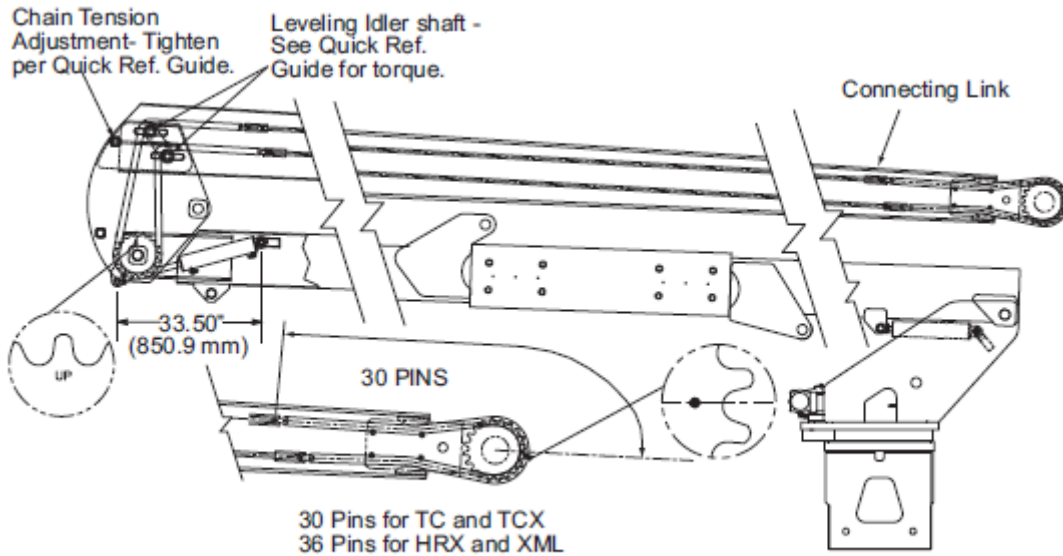

Refer to Leveling System Chain Tension in Quick Reference Guide.

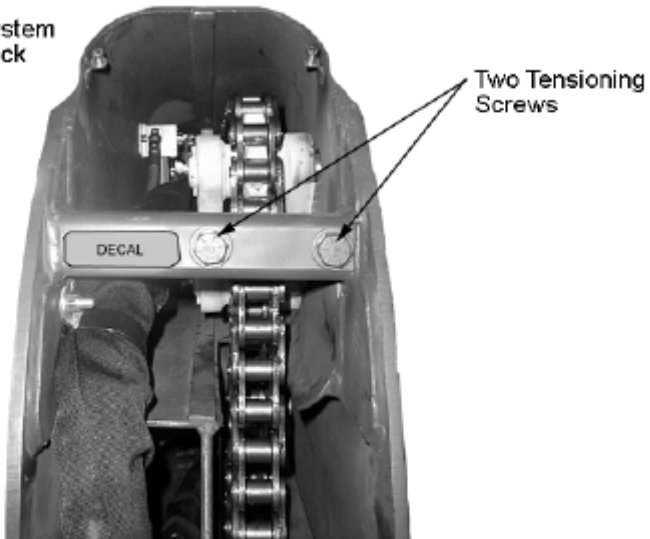

END VIEW OF UPPER BOOM SHOWING TENSION SCREWS



## STEP 5

Clean the chains and remove any excessive build-up of oil, grease, or debris. Do not steam clean or use degreasers. Use a petroleum solvent, diesel fuel, or kerosene.

## STEP 6

Using instructions in the unit specific maintenance manual, inspect the chain. The chain should not be stiff at any point, all links must move freely, and the chain must lay straight on the bench. Ensure all rollers spin freely, and check for any that are loose.

## STEP 7

Stretch the chain slightly and then measure the chain per instructions below to check for elongation. As the chain may not wear evenly, take several measurements along its length. If any one pin joint shows more wear and movement than other links, replace the chain.

### MEASURING CHAIN ELONGATION

1. The chain should be measured by stretching it slightly.
2. Measure the distance, using a vernier, on the inside (L1) and outside (L2) of rollers at both ends of the measured links, to get measurement (L).  
 $L = (L1 + L2) / 2$
3. Calculate the standard length.  
Standard Length = Chain Pitch x Number of Pitches
4. Chain elongation can then be calculated.  
**Chain Elongation = (Measured Length - Standard Length) / Standard Length x 100%**

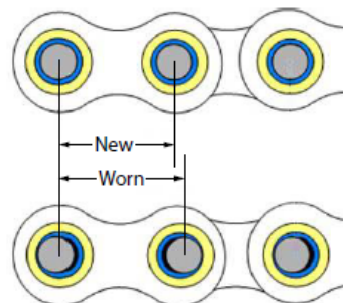
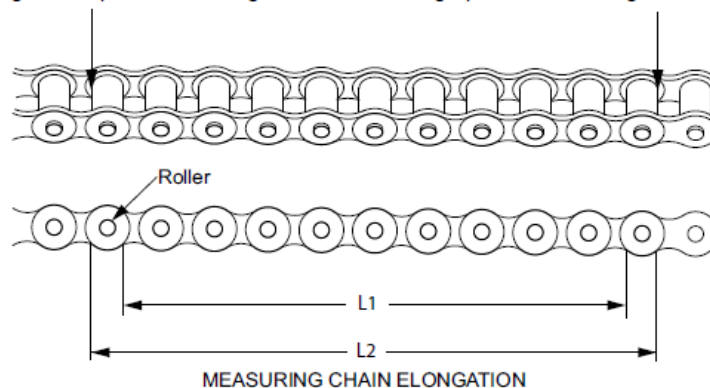

NOTE: When measuring, use at least 10 pitches to help keep any measuring error to a minimum.





**Chain Stretched for Measuring**

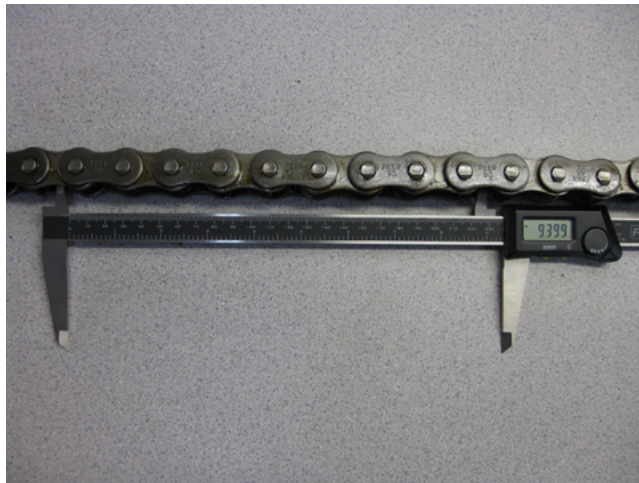

**Measuring L1 Dimension**

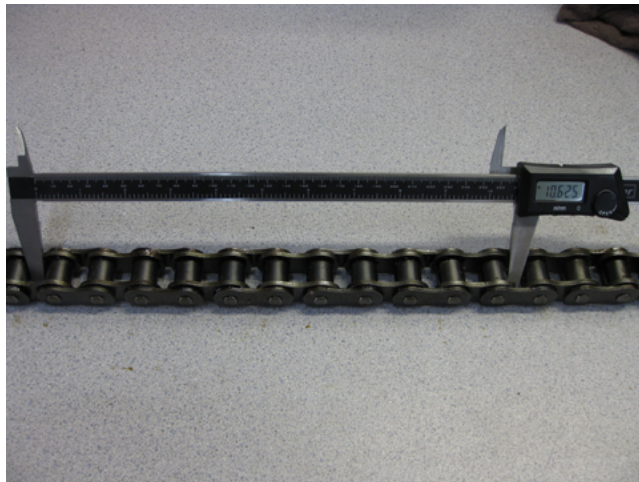

**Measuring L2 Dimension**

## STEP 7 (Continued)

Using the measurements in the pictures on the previous page:

$$L1 = 9.399$$

$$L2 = 10.625$$

$$\text{Length} = (L1 + L2) / 2$$

$$\text{Length} = (9.399 + 10.625) / 2 = 10.012$$

**Standard Length** = Chain Pitch x Number of links

- Chain pitch for #80 chain reference the chart: 1.00
- 1.00 x 10 Links = 10.00

**Chain Elongation** = (Measured Length – Standard Length) / Standard Length x 100%

$$\text{Chain Elongation} = (10.012 - 10.000) / 10.000 = .0012 \times 100\% = .12\%$$

---

## STEP 8

After measuring and calculating the elongation, consult the unit specific maintenance manual for the maximum allowable chain elongation. All dimensions are in inches.

Using either the 10.012 or .12% values from the example and comparing to the chart below, the chain measured above can be lubed and put back in the unit it was taken out of.

### MAXIMUM ALLOWABLE CHAIN ELONGATION

Determine the chain size from the kitsheet or by examination of the chain to determine wear limit.

DRIVING SPROCKET NUMBER OF TEETH	CHAIN ELONGATION (%)
60 and under	1.5

### STANDARD LENGTH AND 1.5% ELONGATION

CHAIN SIZE		60	80	100	120
PITCH		.75	1.00	1.25	1.50
6 Link Measure	Original	4.500	6.000	7.500	9.000
	1.5% Elongation	4.567	6.090	7.612	9.135
10 Link Measure	Original	7.500	10.000	12.500	15.000
	1.5% Elongation	7.612	10.150	12.687	15.225

## STEP 9

If any measured section is not within tolerance, replace the chain per instructions listed below. Always soak a new chain in 30w non-detergent oil overnight before installing it.

### REPLACEMENT OF CHAINS

1. When replacing a chain, replace the entire chain including master links. DO NOT replace links or build lengths of chain from individual components.
2. DO NOT paint the chain. Although paint may help inhibit external corrosion, it will seal off critical clearances and restrict oil from reaching the internal pin surfaces where it is needed for adequate joint lubrication. Always protect chain from paint when painting unit, especially during new unit installation or unit transfer.
3. Protection from corrosion is important in storage as well as in service. A factory lubricant has been applied to new chains. After installation, the recommended lubricant must be applied to the entire chain.
4. Ensure that other component parts, sprocket, bearing and idler assembly are installed properly per Maintenance and Service Manuals.

## STEP 10

Reinstall chains per the unit specific maintenance manual. The example below is for reference only.

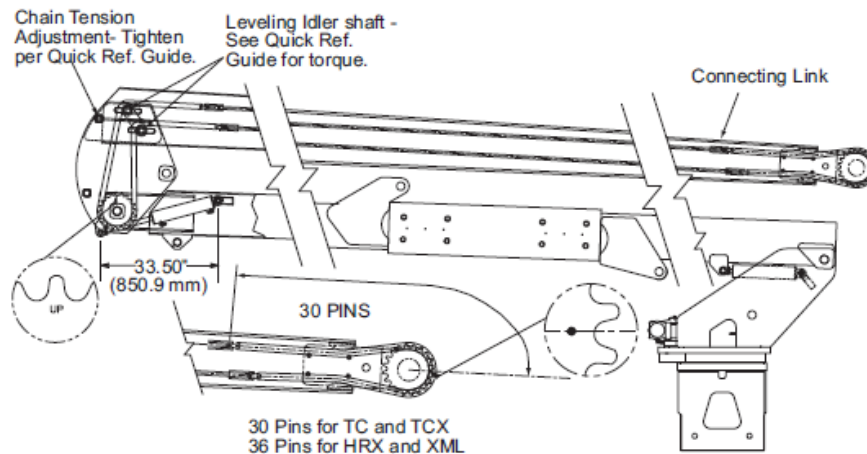

Refer to Leveling System Chain Tension in Quick Reference Guide.

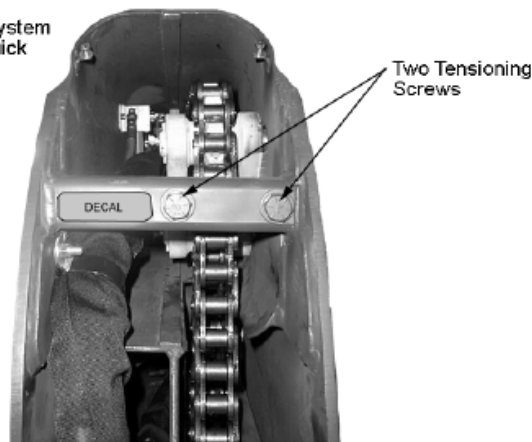

END VIEW OF UPPER BOOM SHOWING TENSION SCREWS

## STEP 11

After installing the chains, operate the unit through the full range of motion, then recheck the tension.



FOR FURTHER ASSISTANCE,  
CONTACT THE TEREX UTILITIES TECHNICAL SUPPORT TEAM  
PHONE: **1-844-TEREX4U (1-844-837-3948)** | EMAIL: [\*\*UTILITIES.SERVICE@TEREX.COM\*\*](mailto:UTILITIES.SERVICE@TEREX.COM)

---