

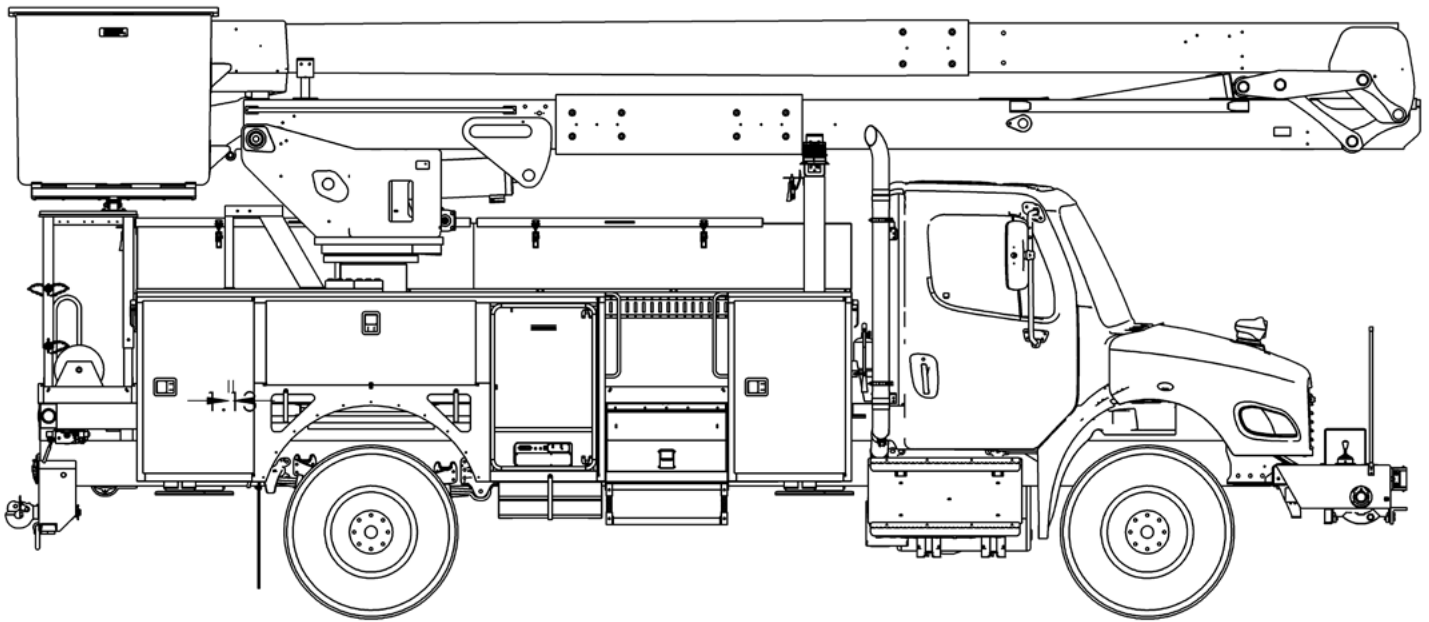

# TECH TIPS

INSPECTING A UNIT THAT HAS MADE ELECTRICAL CONTACT

NO. 56



**SERVICE CALL:**  
INSPECTING A UNIT THAT HAS  
MADE ELECTRICAL CONTACT



**MODEL(S):**  
ALL TEREX UTILITIES EQUIPMENT



**TOOLS NEEDED:**  
DIGITAL CAMERA

TEREX UTILITIES TECHNICAL SUPPORT TEAM

PHONE: 1-844-TEREX4U (1-844-837-3948) | EMAIL: [UTILITIES.SERVICE@TEREX.COM](mailto:UTILITIES.SERVICE@TEREX.COM)



## DANGER

Failure to obey the instructions and safety rules in the appropriate Operator's Manual and Service Manual for your machine will result in death or serious injury.

Many of the hazards identified in the Operator's Manual are also safety hazards when maintenance and repair procedures are performed.

## DO NOT PERFORM MAINTENANCE UNLESS:

- ✓ You are trained and qualified to perform maintenance on this machine.
- ✓ You read, understand and obey:
  - manufacturer's instructions and safety rules
  - employer's safety rules and worksite regulations
  - applicable governmental regulations
- ✓ You have the appropriate tools, lifting equipment and a suitable workshop.

The information contained in this Tech Tip is a supplement to the Service Manual. Consult the appropriate Service Manual of your machine for safety rules and hazards.

 **WARNING**



**Injection Hazard**

Fluid escaping under pressure can penetrate skin and result in death or serious injury.



Relieve pressure before disconnecting hydraulic lines.

Stay clear of leaks and pin holes. Use a piece of cardboard or wood to search for leaks. Do not use hand.

Fluid injected into skin must be surgically removed within a few hours by a doctor familiar with this type of injury, or gangrene will result.



TECH TIP 56 | RELEASED 02.27.2022 | VERSION 1.0  
©TEREX UTILITIES. ALL RIGHTS RESERVED

# CONTENTS

## TECH TIP #56

### TOC

4

- | Take the unit out of service
- | Determine entrance and exit points
- | Take pictures of carbon tracking
- | Inspect the interior of the boom

**INTRODUCTION**  
**STEP 1 - STEP 5**

5

- | Inspect all components between contact points
- | Contact the manufacturer

**STEP 6 - STEP 8**

## INTRODUCTION

This Tech Tip offers some guidelines on inspecting the extent of damage on a unit that has made electrical contact such as with energized powerlines. This includes phase to phase, phase to neutral, and phase to ground electrical contact.

## STEP 1

Take the unit out of service until it has been inspected and all repairs are made by a qualified technician.

If an injury has occurred, notify the manufacturer of the unit.

## STEP 2

Determine entrance and exit points of electrical current. Gather all the information about the contact by talking with the operator. Thoroughly inspect boom, tower, subframe, and chassis before operating unit.

---

## STEP 3

Take pictures of any carbon tracking on the boom if present. Then clean any soot from fiberglass boom(s) per the maintenance manual and perform a dielectric test. If the boom(s) fail the dielectric test, replacement may be needed due to tracking. See Tech Tip 51 for more information on booms that fail the dielectric test.

## STEP 4

If the metal portion of the boom has arc marks: take pictures of the marks and note the location, measure size, and depth of erosion for submission to the manufacturer for evaluation.

## STEP 5

A flashover may have occurred inside the boom. Inspect the interior of the boom(s) for any evidence of a flashover. Document any damaged components and the size and location of any discolored paint.

## STEP 6

All components will need to be inspected between points of contact and inspected carefully for arc marks. This includes but is not limited to: cylinders and boom pivot points.

## STEP 7

If both points of contact are not identified, all components from point of contact to ground level will need to be inspected for arc marks.

This may include but is not limited to: all boom pivot points, boom cylinders, rotations bearing and fastener, complete leveling system, outriggers and their cylinders, gearboxes, electric and hydraulic swivel joints.



Escaping fluid under pressure can penetrate skin causing serious injury.

Relieve pressure before disconnecting hydraulic lines. Keep away from leaks and pin holes. Use a piece of cardboard or paper to search for leaks. DO NOT use your hand.

## STEP 8

Once all of the information has been gathered, contact the unit manufacturer to determine what other steps must be taken.

If you have any questions on the proper procedure or the extent of damage, contact the unit manufacturer for more information.

If the unit is a Terex aerial device, digger derrick, or a pressure digger contact the Service Department at: (800) 982-8975. If the unit is manufactured by another manufacturer, contact their service department.

Provide the owner with a documented inspection report including any dielectric testing and repairs performed.



FOR FURTHER ASSISTANCE,  
CONTACT THE TEREX UTILITIES TECHNICAL SUPPORT TEAM  
PHONE: **1-844-TEREX4U (1-844-837-3948)** | EMAIL: **[UTILITIES.SERVICE@TEREX.COM](mailto:UTILITIES.SERVICE@TEREX.COM)**

---