

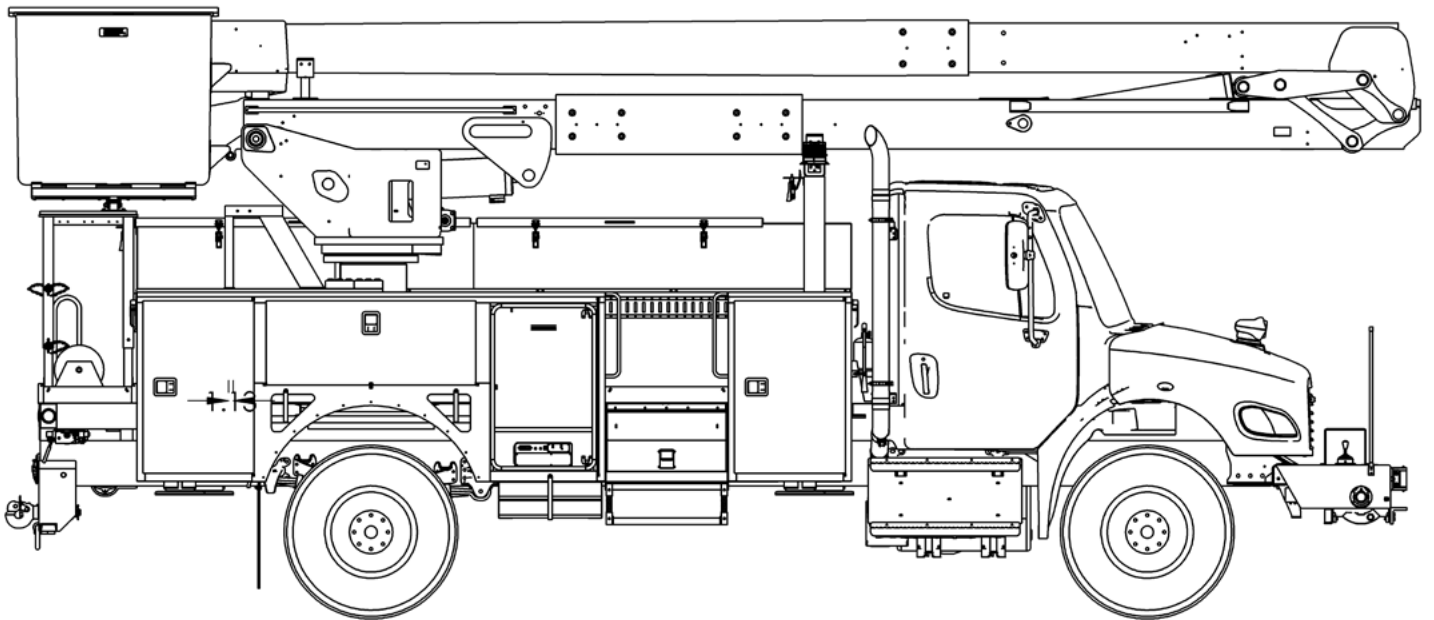

# TECH TIPS

CUSTOMER AND DISTRIBUTOR UNIT FOLDER ACCESS

# NO. 50



**SERVICE CALL:**  
CUSTOMER AND DISTRIBUTOR  
UNIT FOLDER ACCESS



**MODEL(S):**  
ALL TEREX UTILITY UNITS  
PRODUCED SINCE 09/1997



**TOOLS NEEDED:**  
COMPUTER/INTERNET ACCESS  
COMPANY SPECIFIC EMAIL  
ADDRESS

TEREX UTILITIES TECHNICAL SUPPORT TEAM

PHONE: 1-844-TEREX4U (1-844-837-3948) | EMAIL: [UTILITIES.SERVICE@TEREX.COM](mailto:UTILITIES.SERVICE@TEREX.COM)



## **DANGER**

Failure to obey the instructions and safety rules in the appropriate Operator's Manual and Service Manual for your machine will result in death or serious injury.

Many of the hazards identified in the Operator's Manual are also safety hazards when maintenance and repair procedures are performed.

## **DO NOT PERFORM MAINTENANCE UNLESS:**

- ✓ You are trained and qualified to perform maintenance on this machine.
- ✓ You read, understand and obey:
  - manufacturer's instructions and safety rules
  - employer's safety rules and worksite regulations
  - applicable governmental regulations
- ✓ You have the appropriate tools, lifting equipment and a suitable workshop.

The information contained in this Tech Tip is a supplement to the Service Manual. Consult the appropriate Service Manual of your machine for safety rules and hazards.



TECH TIP 50 | RELEASED 10.31.2022 | VERSION 1.1  
©TEREX UTILITIES. ALL RIGHTS RESERVED

# CONTENTS

## TECH TIP#50

### TOC

4

| Register for an account

**INTRODUCTION  
STEP 1 - STEP 2**

5

| Complete registration form

**STEP 3**

6

| Activate your account

| Reset password

**STEP 3 - STEP 5**

7

| Unit Folder Search

**STEP 6**

8

**EXAMPLE 1**

9

**EXAMPLE 2  
TECH-TIPS  
KIT SHEET SEARCH**

## INTRODUCTION

Terex Utilities is now offering Unit Folder access to all customers and distributors through our internet portal!

**Note:** This only applies to units with a 10-digit serial number. Refer to **Tech-tip 25** for more information on serial number formatting for older units produced by Hi-Ranger and Tel-elect.

## STEP 1

[Click here to register for an account.](#)

## STEP 2

Click on the “Register” link.

Welcome

Login

Register



FIGURE 1

### STEP 3

Complete the registration form with your name, company, email address and phone number.

**Note:** A company specific email address is required to request an account on the portal. Generic email accounts from Gmail, Yahoo, Live, etc. will not be approved. The email address must also belong to an individual, not a group such as parts@mycompany.com.

*\* Indicates a required field.*

\* First Name:

\* Last Name:

\* Company Name:

\* Email:

\* Email (Again):

\* Phone:

\* Terms:  I agree to the **Terms & Conditions**

**FIGURE 2**

## STEP 4

Once registration is complete, you'll see the following message:

### Registration

Thanks for registering for an account on the Terex Utilities Portal Website.

Your registration will be reviewed within 1 business day. Upon successful validation, you will receive an email to create a password and complete the registration.

At this point, the request is submitted for authorization by Terex. Within 1 business day you will receive an email allowing you to set your password if your account is approved.

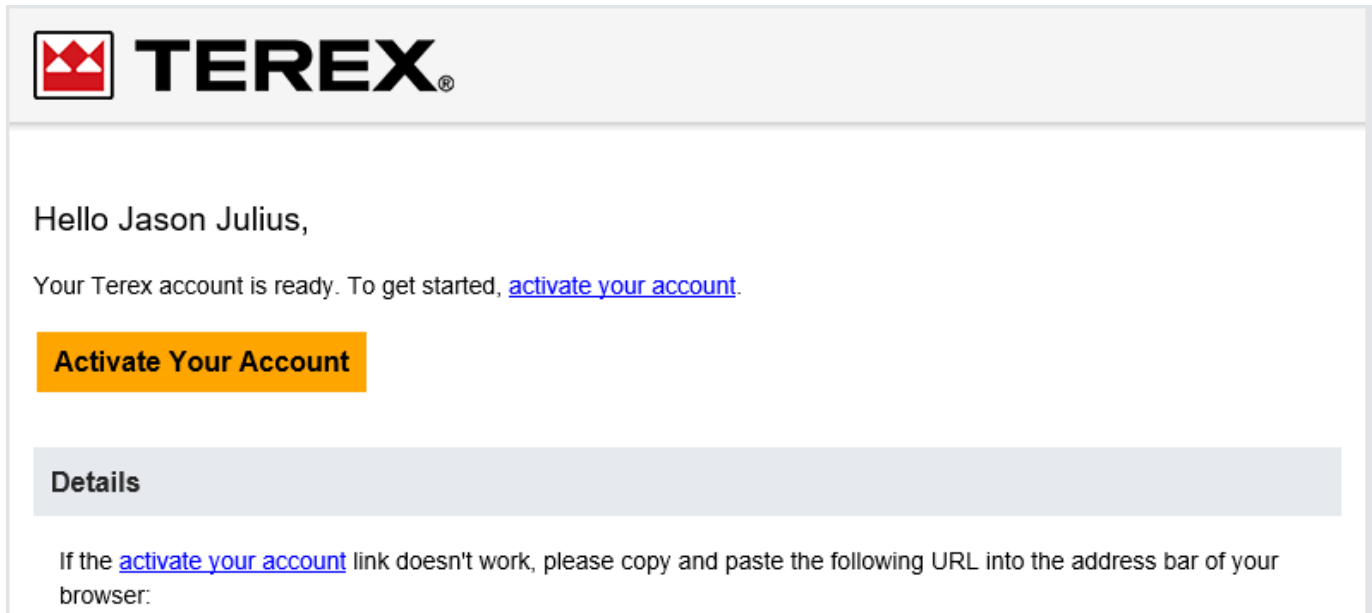

The screenshot shows an email header with the Terex logo (a red square with a white crown-like shape) and the word "TEREX" in bold black letters. Below the header, the email body contains the following text: "Hello Jason Julius," followed by "Your Terex account is ready. To get started, [activate your account](#)." Below this is a prominent orange button with the text "Activate Your Account" in white. Underneath the button is a grey bar with the word "Details" in white. At the bottom of the email body, it says: "If the [activate your account](#) link doesn't work, please copy and paste the following URL into the address bar of your browser:"

Clicking on the Activate Your Account link will allow you to reset the password for the account and login.

**Note:** If your account is rejected, then you'll receive an email with the reason why the account has been rejected.

## STEP 5

Once you have created your password you can login to the system.

## STEP 6 - Accessing Information

### UNIT FOLDER SEARCH

To search for your unit, enter in the letters DK and the last 5 numbers of your unit serial number.

Please Enter Your Unit Folder Number

(Example entry: DK10001)

Search

Back

For each specific unit you will have access to the following folders if available:

- Campaign Bulletins
  - Links to any bulletins related to the specific unit
- Certificate of Conformity
- Kit Sheets
- Operator and Maintenance Manuals
- ID Placard
- Chassis Information
- Load Chart

## Unit Folder DK58419

---

**UNIT FOLDER #:** DK58419  
**TSD DISTRIBUTOR:** TEREX UTILITIES SOUTH  
**TUI DISTRIBUTOR:** CUSTOM TRUCK & EQUIPMENT, L  
**CUSTOMER:** TEREX STOCK  
**UNIT TYPE:** LT40  
**ORDERED:** 04/29/16  
**SHIPPED:** 12/28/18

### Click on the following links to display:

[Drawings and Schematics](#)  
[Certificate of Conformity](#)  
[Kit Sheet Breakdown by Code](#)  
[Interactive Parts Manual](#)  
[Operators Manual](#)  
[Maintenance Manual](#)  
[ID Plate](#)  
[Bill of Material for Ship Loose Parts](#)  
[Bill of Material for Ship Loose Parts Paperwork](#)  
[Photo Gallery](#)  
[Chassis Check-In Form](#)

[Back to Search Screen](#)

### EXAMPLE 1

\*All links may not be available for specific units.



## Unit Folder DK32728

---

**UNIT FOLDER #:** DK32728  
**TSD DISTRIBUTOR:** No Header Information Available  
**TUI DISTRIBUTOR:** No Header Information Available  
**CUSTOMER:** QUANTA SERVICES INC.  
**UNIT TYPE:** C4000  
**ORDERED:** 09/25/06  
**SHIPPED:** 01/19/07

### Click on the following links to display:

[Certificate of Conformity](#)  
[Load Chart](#)  
[Kit Sheet Breakdown by Code](#)  
[Operators Manual](#)  
[Maintenance Manual](#)  
[Final Test and Inspection](#)  
[ID Plate](#)  
[Bill of Material for Ship Loose Parts](#)  
[Chassis Check-In Form](#)

[Back to Search Screen](#)

### EXAMPLE 2

### TECH-TIPS

Links to the tech-tips section of our public website.

### KIT SHEET SEARCH

Enter a part number to search for the corresponding kit sheet.

Please Enter Your Part Number

(Example entry: 42100)

Search

Back



FOR FURTHER ASSISTANCE,  
CONTACT THE TEREX UTILITIES TECHNICAL SUPPORT TEAM  
PHONE: **1-844-TEREX4U (1-844-837-3948)** | EMAIL: **[UTILITIES.SERVICE@TEREX.COM](mailto:UTILITIES.SERVICE@TEREX.COM)**

---