

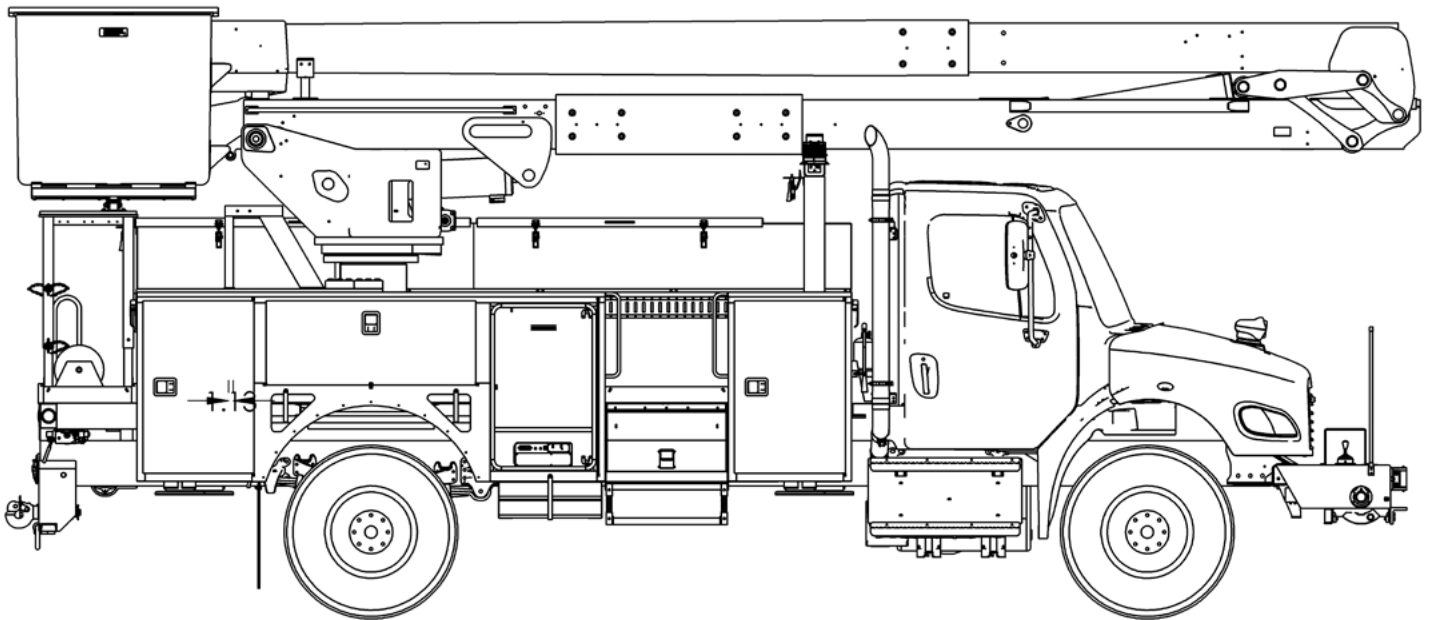

# TECH TIPS

ROTATION BEARING DEFLECTION TEST

NO. 45



**SERVICE CALL:**  
ROTATION BEARING DEFLECTION  
TEST



**MODEL(S):**  
TPL 29, TPL 33, TE/TS



**TOOLS NEEDED:**  
DIAL INDICATOR/MAGNETIC BASE  
UNIT SPECIFIC MAINT. MANUAL  
DYNAMOMETER  
CRANE OR DIGGER DERRICK  
FOR LIFTING BOOM (NEGATIVE  
DEFLECTION)

TEREX UTILITIES TECHNICAL SUPPORT TEAM

PHONE: 1-844-TEREX4U (1-844-837-3948) | EMAIL: [UTILITIES.SERVICE@TEREX.COM](mailto:UTILITIES.SERVICE@TEREX.COM)



## **DANGER**

Failure to obey the instructions and safety rules in the appropriate Operator's Manual and Service Manual for your machine will result in death or serious injury.

Many of the hazards identified in the Operator's Manual are also safety hazards when maintenance and repair procedures are performed.

## **DO NOT PERFORM MAINTENANCE UNLESS:**

- ✓ You are trained and qualified to perform maintenance on this machine.
- ✓ You read, understand and obey:
  - manufacturer's instructions and safety rules
  - employer's safety rules and worksite regulations
  - applicable governmental regulations
- ✓ You have the appropriate tools, lifting equipment and a suitable workshop.

The information contained in this Tech Tip is a supplement to the Service Manual. Consult the appropriate Service Manual of your machine for safety rules and hazards.



TECH TIP 45 | RELEASED 07.18.2022 | VERSION 1.0  
©TEREX UTILITIES. ALL RIGHTS RESERVED

# CONTENTS

## TECH TIP #45

### TOC

4

| Position the unit  
| Check for obstructions

**STEP 1 - STEP 3**

5

| Attach a dynamometer

**STEP 4**

6

| Attach the dial indicator

**STEP 5**

7

| Pull up on boom  
| Zero out dial indicator  
| Remove upward force and extend  
| Read the dial indicator

**STEP 6 - STEP 9**

## STEP 1

Read this entire procedure and the section in the maintenance manual that applies to this procedure before starting the work.

## STEP 2

Position the truck in a suitable location, check for overhead obstructions, and set the outriggers. There can be no additional tools or materials in the platform, except for a platform liner.

## STEP 3

Check for obstructions before rotating the boom. Rotate the boom 90 degrees off the side or rear of the vehicle. Place upper boom at 0 degrees with boom extension fully retracted.

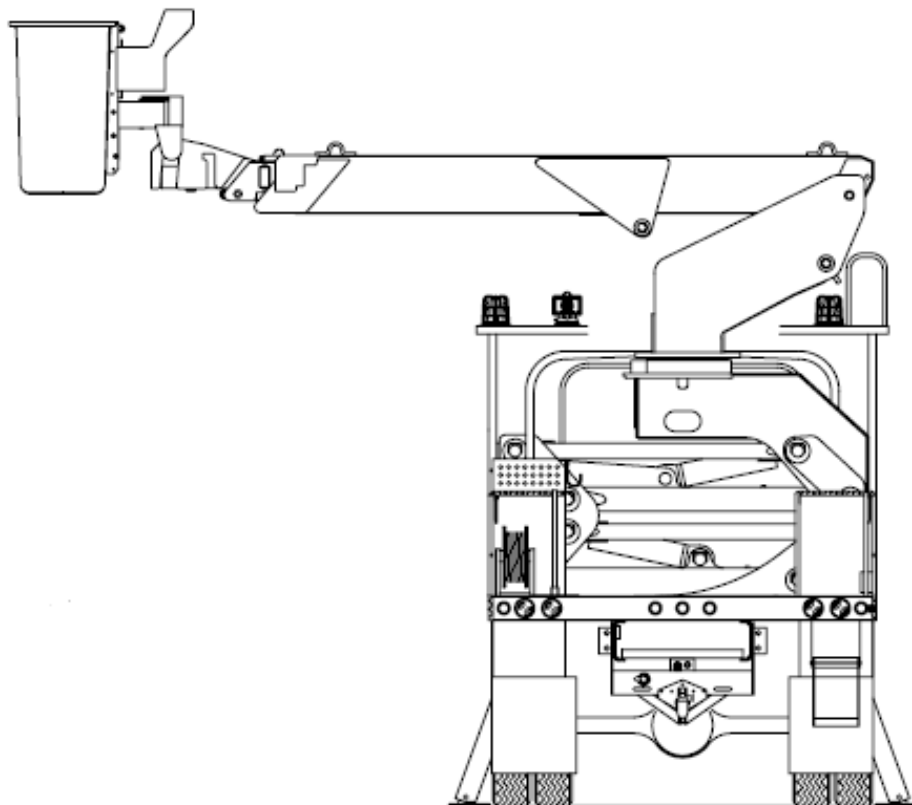

## STEP 4

Attach a dynamometer between the boom tip and the load line for pulling up the boom (negative deflection).

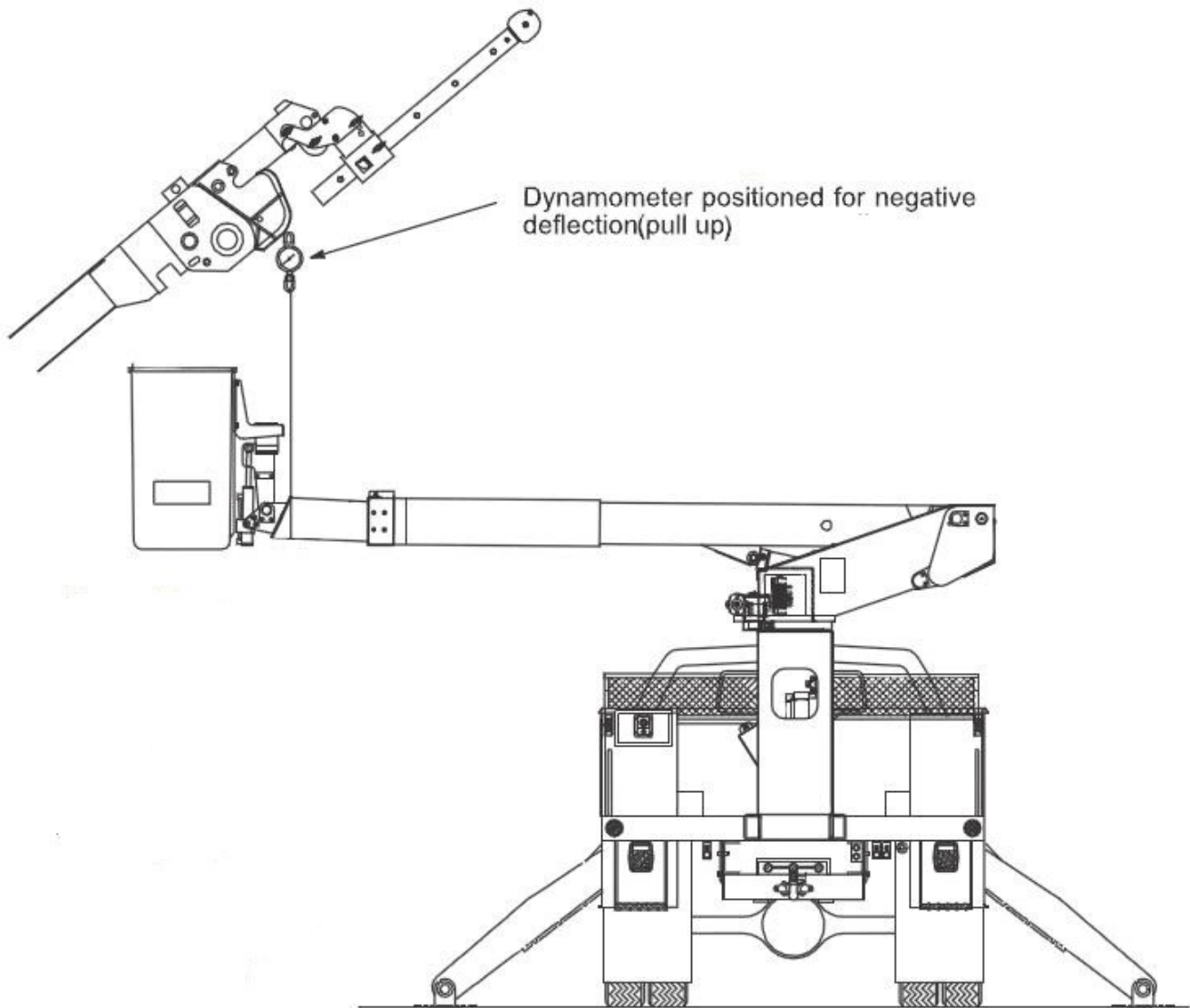

## STEP 5

Attach the dial indicator base to the pedestal, positioning the tip perpendicular to the edge of the turntable bottom plate at the specified indicator radius.

Note: Consult the table at the end of this document for the dial indicator radius for your specific unit.

Note: Ensure you know which way the dial indicator will rotate when performing the test to get the correct reading.

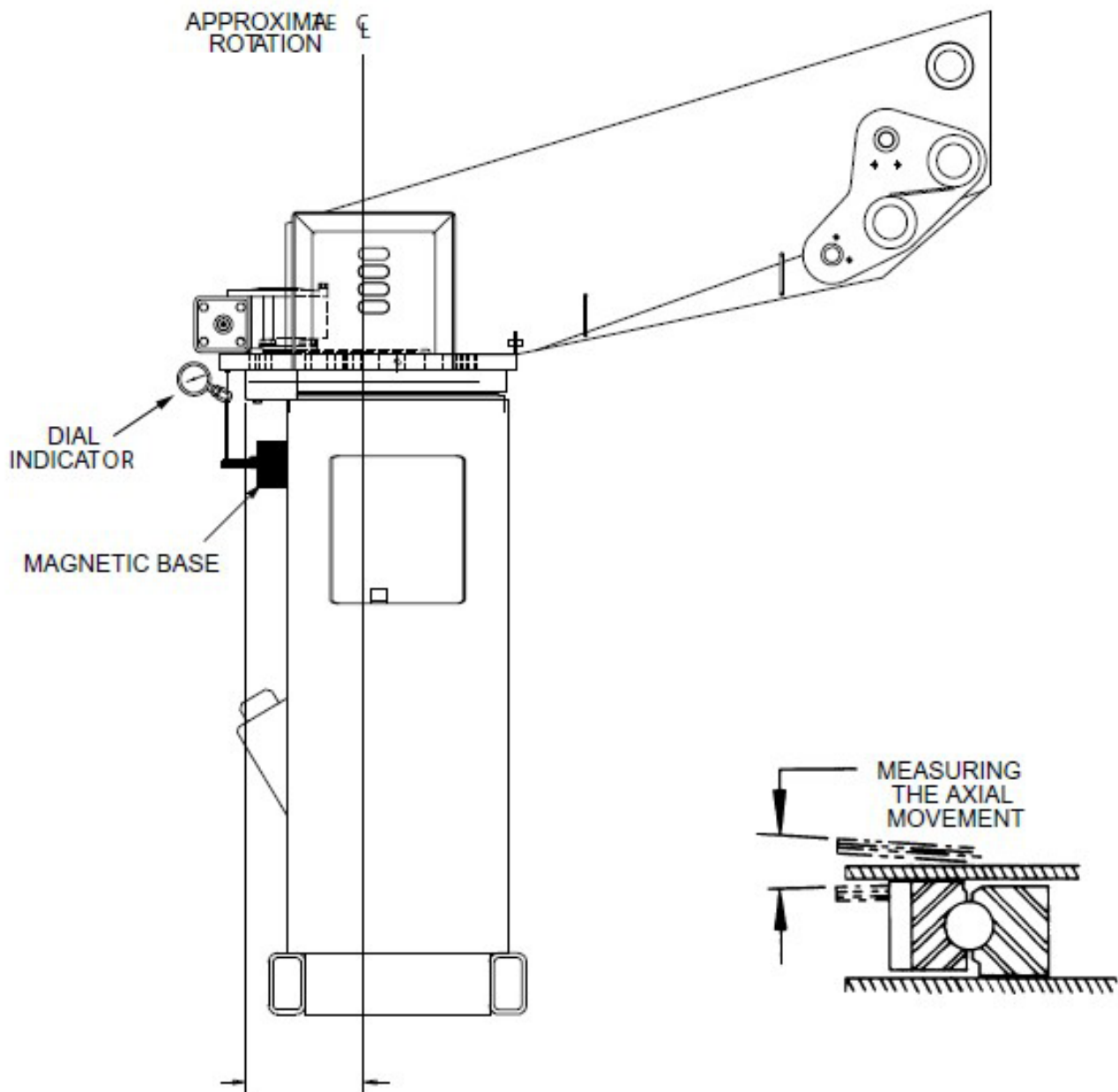

## STEP 6

Pull up gently on the boom using a Crane or Digger Derrick, with the dynamometer installed on the load line.

Note: Do not exceed the value specified in the unit specific maintenance manual.

## STEP 7

Zero out the dial indicator. Verify that you have at least .25 inches of movement on the dial indicator in both directions when zeroing.

## STEP 8

Remove the upward force on boom from the Crane or Digger Derrick. Extend boom fully.

## STEP 9

Read the number on the dial indicator. This is your rotation bearing deflection. Record the reading and check this reading against the "Maximum Allowable Bearing Deflection" in the following table.

Note: Measure the deflection at the same boom location and dial indicator radius every time this test is performed to provide consistent measurements that can be compared over the life of the machine.

Unit Model	Maintenance Manual	Indicator Radius (inch)	Max Deflection (inch)
TPL	463668	11.50	0.176
TE/TS	463312	12.75	0.160

**Unit Specific Maximum Allowable Bearing Deflection**



FOR FURTHER ASSISTANCE,  
CONTACT THE TEREX UTILITIES TECHNICAL SUPPORT TEAM  
PHONE: **1-844-TEREX4U (1-844-837-3948)** | EMAIL: [UTILITIES.SERVICE@TEREX.COM](mailto:UTILITIES.SERVICE@TEREX.COM)

---