

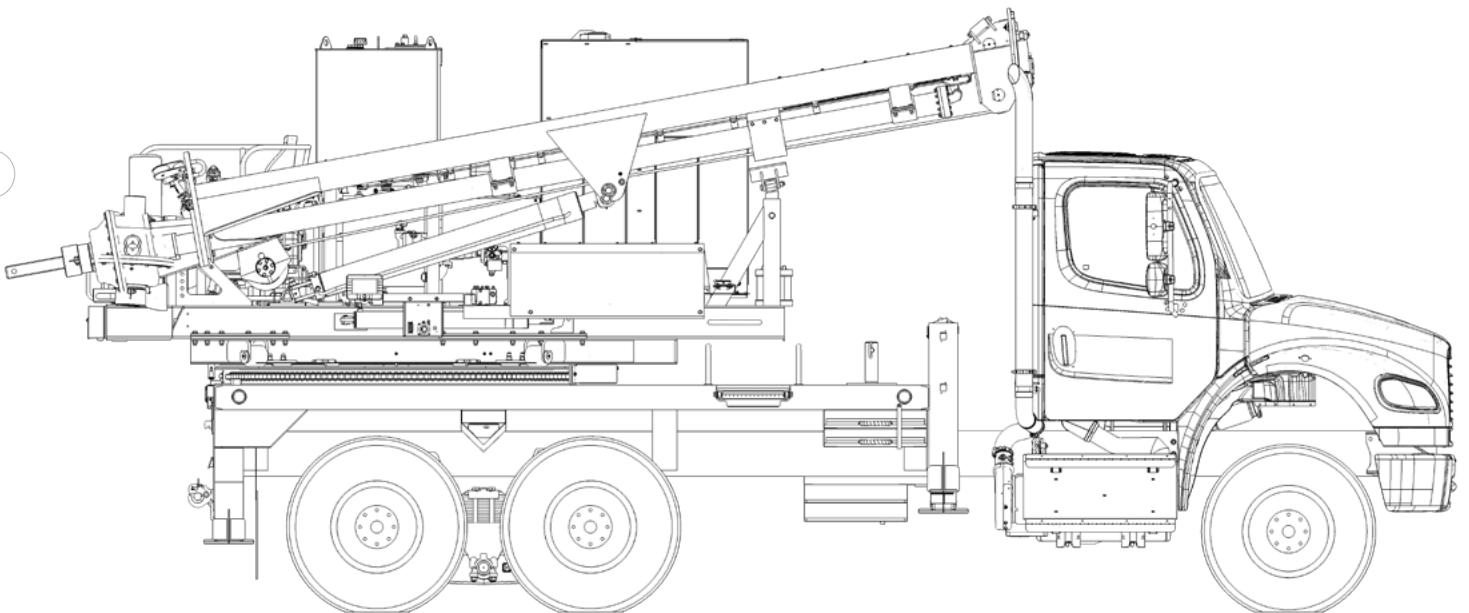

TECH TIPS

BULLET TOOTH REMOVAL AND INSTALLATION

NO. 36



**SERVICE CALL:
BULLET TOOTH REMOVAL AND
INSTALLATION**



**MODEL(S):
TEREX UTILITIES BULLET TOOTH
AUGERS**



**TOOLS NEEDED:
BRASS HAMMER
TOOTH PULLER
PUNCH**

TEREX UTILITIES TECHNICAL SUPPORT TEAM

PHONE: 1-844-TEREX4U (1-844-837-3948) | EMAIL: UTILITIES.SERVICE@TEREX.COM



DANGER

Failure to obey the instructions and safety rules in the appropriate Operator's Manual and Service Manual for your machine will result in death or serious injury.

Many of the hazards identified in the Operator's Manual are also safety hazards when maintenance and repair procedures are performed.

DO NOT PERFORM MAINTENANCE UNLESS:

- ✓ You are trained and qualified to perform maintenance on this machine.
- ✓ You read, understand and obey:
 - manufacturer's instructions and safety rules
 - employer's safety rules and worksite regulations
 - applicable governmental regulations
- ✓ You have the appropriate tools, lifting equipment and a suitable workshop.

The information contained in this Tech Tip is a supplement to the Service Manual. Consult the appropriate Service Manual of your machine for safety rules and hazards.



TECH TIP 36 | RELEASED 03.17.2022 | VERSION 1.0
©TEREX UTILITIES. ALL RIGHTS RESERVED

CONTENTS

TECH TIP #36

TOC

4

| *Removing bullet teeth*

INTRODUCTION
STEP 1

5

| *Installing bullet teeth*

STEP 2

6

| *Verify the tooth rotates freely*

STEP 3

INTRODUCTION

- Always wear safety glasses and gloves when removing or installing teeth
- Never strike a tooth with a hammer or other hard object

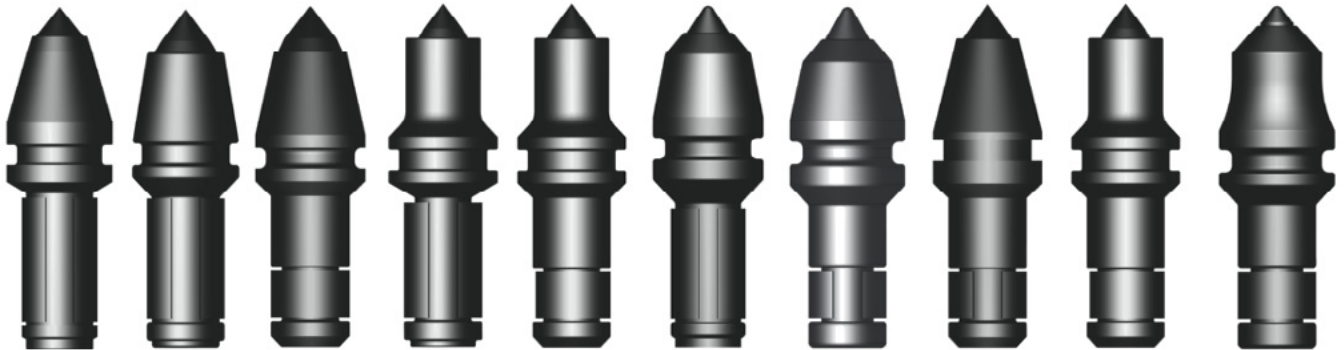

STEP 1

Removing Bullet Teeth

Method 1: Using a tooth puller.

Slide the opening of the tooth puller onto the tooth groove so that it seats firmly, Strike the tooth puller firmly with a hammer to remove the tooth.



STEP 1 (CONTINUED)

Method 2: Using a hammer punch.

Place the tip of the hammer punch in the pocket at the back of the tooth. Strike the punch with a hammer to remove the tooth.



STEP 2

Installing Bullet Teeth

Note: Coat the tooth shank with an anti-seize compound before installing to prevent the tooth from seizing in the pocket. This also provides lubrication to improve tooth rotation during drilling operations.

Method 1: Using a Tooth Installer

Using the tooth installer, position the tooth over the opening and strike the installer with a hammer to install the tooth.



STEP 2 (CONTINUED)

Method 2: Using a Brass Hammer

Place the brass hammer against the tooth tip and strike the brass hammer to install.



STEP 3

Verify that the tooth rotates freely in the pocket after installation. If the tooth binds, remove the tooth and check for damage.



FOR FURTHER ASSISTANCE,
CONTACT THE TEREX UTILITIES TECHNICAL SUPPORT TEAM
PHONE: **1-844-TEREX4U (1-844-837-3948)** | EMAIL: **UTILITIES.SERVICE@TEREX.COM**
