

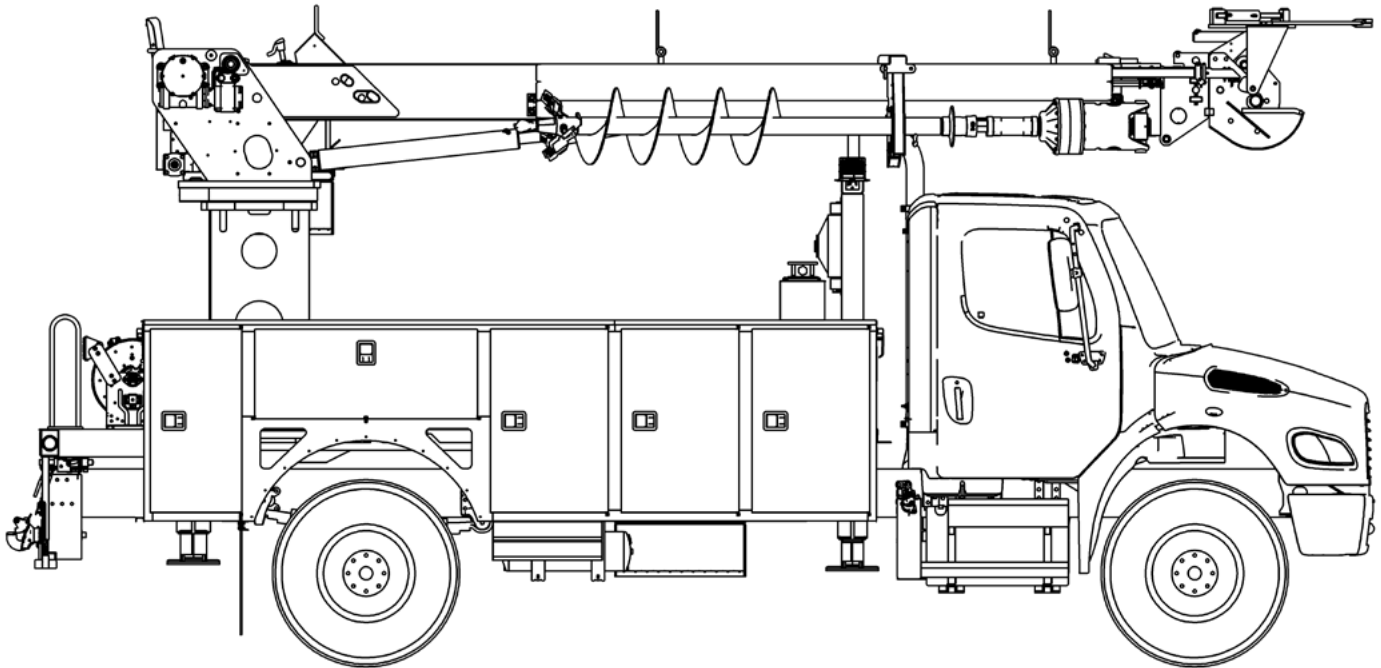

TECH TIPS

REPLACE BENT PG WINCH OR DIGGER SLIDING TUBE ASSEMBLY

NO. 26



SERVICE CALL:
REPLACE BENT PG WINCH OR
DIGGER SLIDING TUBE ASSEMBLY



MODEL(S):
C4000, C500, AND C6000



TOOLS NEEDED:
OPEN-END WRENCHES TO 1-1/2"
BASIC HAND TOOLS
CALIBRATED PRESSURE GAUGE
0-5000PSI
JIC PLUGS AND CAPS OF
VARIOUS SIZES

TEREX UTILITIES TECHNICAL SUPPORT TEAM

PHONE: 1-844-TEREX4U (1-844-837-3948) | EMAIL: UTILITIES.SERVICE@TEREX.COM

! WARNING



Injection Hazard
Fluid escaping under pressure can penetrate skin and result in death or serious injury.



Relieve pressure before disconnecting hydraulic lines.
Stay clear of leaks and pin holes. Use a piece of cardboard or wood to search for leaks. Do not use hand.
Fluid injected into skin must be surgically removed within a few hours by a doctor familiar with this type of injury, or gangrene will result.



DANGER

Failure to obey the instructions and safety rules in the appropriate Operator's Manual and Service Manual for your machine will result in death or serious injury.

Many of the hazards identified in the Operator's Manual are also safety hazards when maintenance and repair procedures are performed.

DO NOT PERFORM MAINTENANCE UNLESS:

- ✓ You are trained and qualified to perform maintenance on this machine.
- ✓ You read, understand and obey:
 - manufacturer's instructions and safety rules
 - employer's safety rules and worksite regulations
 - applicable governmental regulations
- ✓ You have the appropriate tools, lifting equipment and a suitable workshop.

The information contained in this Tech Tip is a supplement to the Service Manual. Consult the appropriate Service Manual of your machine for safety rules and hazards.



TECH TIP 26 | RELEASED 03.09.2022 | VERSION 1.0
©TEREX UTILITIES. ALL RIGHTS RESERVED

CONTENTS

TECH TIP#26

TOC

4

| Assembly
| Remove sliding tube covers

INTRODUCTION
STEP 1 - STEP 2

5

| Remove assembly
| Verify maximum digger and winch pressure
| Check pressure and adjust.

STEP 3 - STEP 5

6

| Reconnect hoses and install tube covers

STEP 6
CONCLUSION

INTRODUCTION

Sliding tubes are hydraulic oil carriers used to send hydraulic oil to an actuator and return the hydraulic oil using a directional control valve connected to the sliding tubes.

The sliding tube assembly is comprised of an inner and an outer tube. The outer tube gland holds the hydraulic oil seal against the smooth chrome finish of the inner tube.

Both the inner and outer tubes have JIC bulkhead fittings used to fasten the tubes to weldments on the main boom and the second stage or auger hanger bracket.

The sliding tubes are assembled onto a carrier weldment, which has guides and supports for the sliding tubes. The cover is very important to guide the tubes.

STEP 1

Manuever the boom into an easily accessible position. Turn the PTO and the engine OFF.

STEP 2

Remove sliding tube covers and disconnect the hydraulic hoses from the sliding tubes, cap and plug as needed. Do not extend or retract the boom with tubes capped, this will trap hydraulic oil inside the sliding tube assembly and damage the slide tubes or supports.



Escaping fluid under pressure can penetrate skin causing serious injury.

Relieve pressure before disconnecting hydraulic lines. Keep away from leaks and pin holes. Use a piece of cardboard or paper to search for leaks. **DO NOT** use your hand.

STEP 3

Remove the damaged sliding tube assembly and reinstall the new sliding tube assembly, along with new seals. The seals for each sliding tube will include a tube seal and a wiper seal to keep the dirt out of the system when using the digger sliding tubes assemblies.



Use proper lifting equipment or additional personal when handling heavy loads

STEP 4

Before reconnecting the hydraulic hoses to the sliding tubes, verify the maximum digger pressure and winch pressure while the hoses are still capped.

To check this pressure, install a pressure gauge to measure the digger pressure and winch hydraulic pressure.

STEP 5

Start the engine and engage the PTO. With the hydraulic oil at operating temperature and the engine at idle; slowly pull the control lever for the valve section with the hoses that are currently capped off. The digger pressure or winch pressure should have a maximum of 2300 PSI.

If the pressure does not stop at 2300 PSI, adjust the relief valve accordingly.

Once idle pressure is verified at 2300 PSI, perform the test again at maximum rated pump flow. The maximum digger pressure or winch pressure should not exceed 2300 PSI. Adjust as needed.



Escaping fluid under pressure can penetrate skin causing serious injury.

Relieve pressure before disconnecting hydraulic lines. Keep away from leaks and pin holes. Use a piece of cardboard or paper to search for leaks. **DO NOT** use your hand.

STEP 6

Reconnect all hydraulic hoses onto the sliding tubes and install the sliding tube cover. Verify that the sliding tubes and all components function properly. The mounting hardware needs to be aligned correctly to prevent binding.



Escaping fluid under pressure can penetrate skin causing serious injury.

Relieve pressure before disconnecting hydraulic lines. Keep away from leaks and pin holes. Use a piece of cardboard or paper to search for leaks. **DO NOT** use your hand.

CONCLUSION

It is very important to identify the root cause of a sliding tube failure. If the cause is not identified and corrected, it is likely that the damage will occur again.

Below are some possible reasons for a sliding tube failure:

- Digger/winch pressure set too high
- Too much flow, excessive RPM, or an incorrectly sized hydraulic pump
- Missing guides or hardware, such as a bent guide rod
- Bent or damaged support plates
- Missing/damaged cover
- Excessive wear or play between second stage boom and the main boom or auger hanger
- Misuse of equipment
- Damaged, bent, or flexing attachment brackets

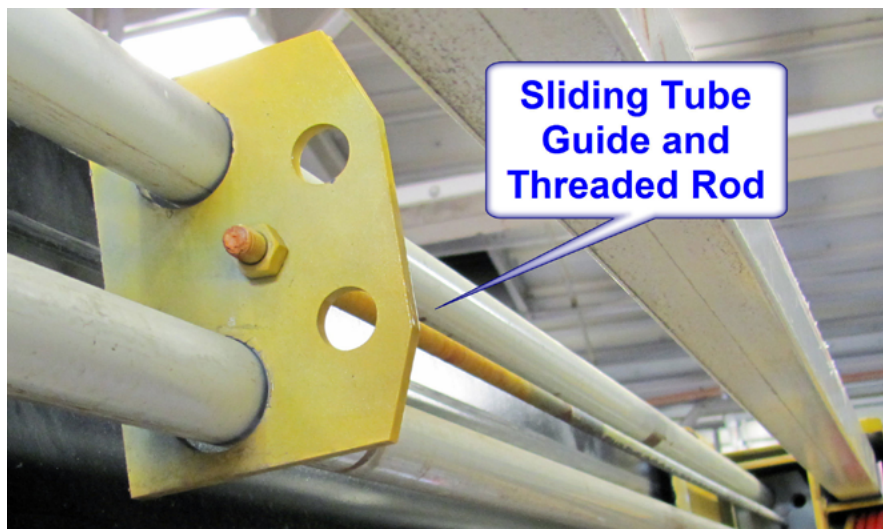



FOR FURTHER ASSISTANCE,
CONTACT THE TEREX UTILITIES TECHNICAL SUPPORT TEAM
PHONE: [1-844-TEREX4U \(1-844-837-3948\)](tel:1-844-TEREX4U) | EMAIL: UTILITIES.SERVICE@TEREX.COM
