

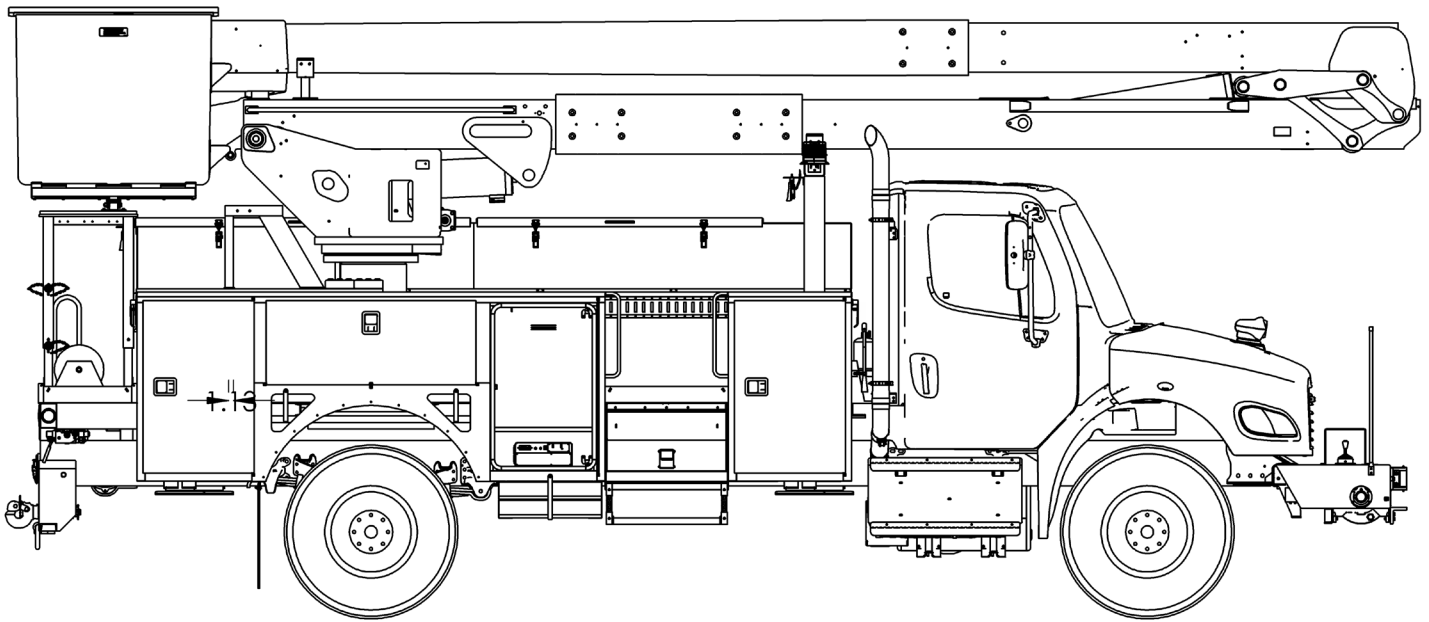

TECH TIPS

PERFORMING A FLOW TEST ON A VALVE ASSEMBLY

NO. 139



SERVICE CALL:
PERFORMING A FLOW TEST ON A
VALVE ASSEMBLY



MODEL(S):
ALL TEREX UTILITIES EQUIPMENT
WITH OPEN CENTER SYSTEMS



TOOLS NEEDED:
BASIC HAND TOOLS
CALIBRATED FLOW METER
RATED FOR THE PROPER FLOW
OIL DRAIN PAN

TEREX UTILITIES TECHNICAL SUPPORT TEAM

PHONE: 1-844-TEREX4U (1-844-837-3948) | EMAIL: UTILITIES.SERVICE@TEREX.COM

! WARNING



Injection Hazard
Fluid escaping under pressure can penetrate skin and result in death or serious injury.

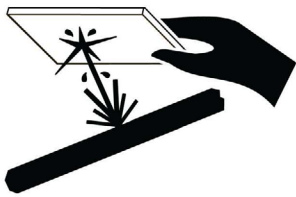

Relieve pressure before disconnecting hydraulic lines.
Stay clear of leaks and pin holes. Use a piece of cardboard or wood to search for leaks. Do not use hand.
Fluid injected into skin must be surgically removed within a few hours by a doctor familiar with this type of injury, or gangrene will result.



DANGER

Failure to obey the instructions and safety rules in the appropriate Operator's Manual and Service Manual for your machine will result in death or serious injury.

Many of the hazards identified in the Operator's Manual are also safety hazards when maintenance and repair procedures are performed.

DO NOT PERFORM MAINTENANCE UNLESS:

- ✓ You are trained and qualified to perform maintenance on this machine.
- ✓ You read, understand and obey:
 - manufacturer's instructions and safety rules
 - employer's safety rules and worksite regulations
 - applicable governmental regulations
- ✓ You have the appropriate tools, lifting equipment and a suitable workshop.

The information contained in this Tech Tip is a supplement to the Service Manual. Consult the appropriate Service Manual of your machine for safety rules and hazards.



TECH TIP 139 | RELEASED 12.11.2023 | VERSION 1.0
©TEREX UTILITIES. ALL RIGHTS RESERVED

CONTENTS

TECH TIP #139

TOC

4

| Close gate valves
| Remove plug

INTRODUCTION
STEP 1 - STEP 3

5

| Install flow meter
| Reinstall plug

STEP 4 - STEP 8

6

| Open gate valves
| Record the reading

STEP 9 - STEP 12

7

| Checking tool flow

XT PRO EXAMPLE

INTRODUCTION

A flow test is performed on a Valve Assembly to determine if it has the proper flow to operate the boom or tool efficiently.

All Terex models have a specific Gallons per Minute (GPM) requirement needed for the boom to operate efficiently. Check the Quick Reference guide in the unit specific manual to determine the correct flow for the specific unit.

There are many different types and sizes of flow meters. A proper flow meter will consist of a calibrated meter, calibrated pressure gauge, and a manual shut-off.

Make sure the flow meter can handle the maximum output flow and pressure of the machine to be tested.

Pressures and flows can be found in the Quick Reference section of the unit specific maintenance manual

STEP 1

Make sure the unit is turned OFF and positioned in a suitable location.

STEP 2

Close the gate valve(s) on the suction line and the return line (if installed).



STEP 3

There may be a plug located on the return filter housing. Remove this plug to allow air into the return line to prevent syphoning.

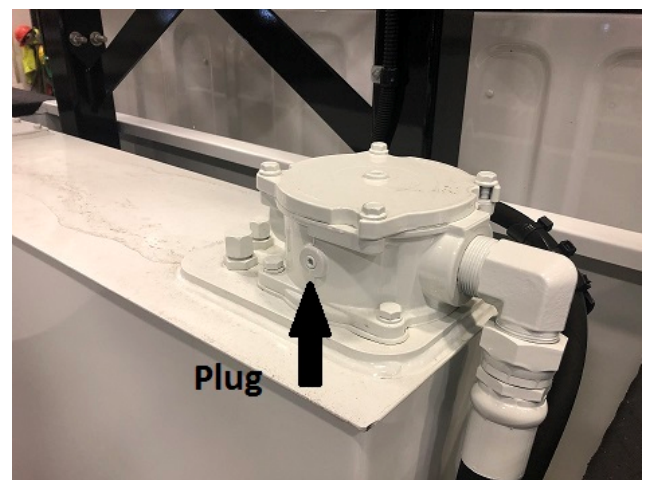

STEP 4

Determine where in the system the flow meter should be installed.

- Tool valve to check/set tool flow for the tool circuit
- Digger valve to see if the Digger head is getting the proper flow

STEP 5

Install the flow meter in line with the inlet or outlet of a valve assembly to see if the proper flow is getting to or out of the valve assembly.

Or

In the work ports of a valve section to see if the proper flow is going to that valve's function.

At this point the flow meter should be installed after the relief cartridge



Escaping fluid under pressure can penetrate skin causing serious injury.

Relieve pressure before disconnecting hydraulic lines. Keep away from leaks and pin holes. Use a piece of cardboard or paper to search for leaks. DO NOT use your hand.

STEP 6

No matter where it is installed make sure flow meter is installed properly so the flow in the meter is going in the right direction. Flow meters will have an inlet and outlet that are labeled.



STEP 7

With flow meter installed in the desired location, make sure the shut off valve on the flow meter is secured in the open position.

STEP 8

Reinstall the plug in the filter housing.

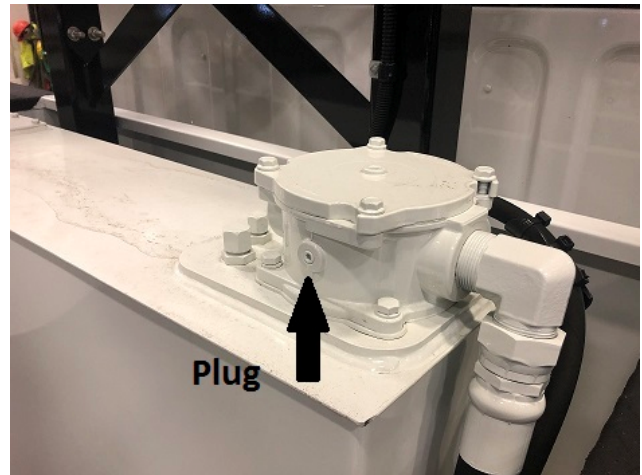

STEP 9

Make sure the gate valve(s) are secured in the open position.

STEP 10

Make sure the gate valve(s) are secured in the open position.

STEP 11

Operate unit to bring the hydraulic fluid to normal operating temperature.



Before operating the unit open the shut off valves and plug any ports removed. Failure to open shut off valves can damage the pump or blow the pump or hoses.

STEP 12

If the Flow Meter is installed in line with the valve assembly record the reading on the flow meter.

Pressures and flows can be found in the Quick Reference section of the unit specific maintenance manual

Using the following chart taken from an XT Pro manual, the flow at idle is 5 GPM and with 2-speed activated it should be 8 GPM.

PRESSURES/FLOWS

Flow at idle	5 GPM (19 LPM)
Hydraulic tool pressure	2250 +/- 25 PSI @ 5 GPM
.....	(15.51 +/- .17 MPa) @ (19 LPM)
Rotation port relief	2000 +/- 50 PSI (13.79 +/- .34 MPa)
System pressure	2750 +/- 50 PSI @ 8 GPM
.....	(18.96 +/- .34 MPa) @ (30 LPM)

Example - Checking Tool Flow on an XT Pro

- Install the flow meter in the tool valve work ports.
- Shift the tool valve handle to operate the tools. According to the manual above, the flow meter should show 5 GPM on the gauge.
- Slowly turn the shut-off valve on the flow meter in the off position to increase the back pressure. The pressure gauge on the flow meter will start to rise and the flow may start to drop.

If the shut off is closed, the pressure setting for the tool circuit is shown. In this example, it should show 2250 psi.

If the shut off valve on the flow meter is closed, the system/circuit relief cartridge should open allowing oil to return to tank and the gauge on the flow meter will read system/circuit pressure.

If the pressure gauge on the flow meter exceeds the recommended pressure setting, STOP and check system pressure and adjust if needed.

PRESSURES/FLOWS

Flow at idle	5 GPM (19 LPM)
Hydraulic tool pressure	2250 +/- 25 PSI @ 5 GPM
.....	(15.51 +/- .17 MPa) @ (19 LPM)
Rotation port relief	2000 +/- 50 PSI (13.79 +/- .34 MPa)
System pressure	2750 +/- 50 PSI @ 8 GPM
.....	(18.96 +/- .34 MPa) @ (30 LPM)



FOR FURTHER ASSISTANCE,
CONTACT THE TEREX UTILITIES TECHNICAL SUPPORT TEAM
PHONE: **1-844-TEREX4U (1-844-837-3948)** | EMAIL: **UTILITIES.SERVICE@TEREX.COM**
