

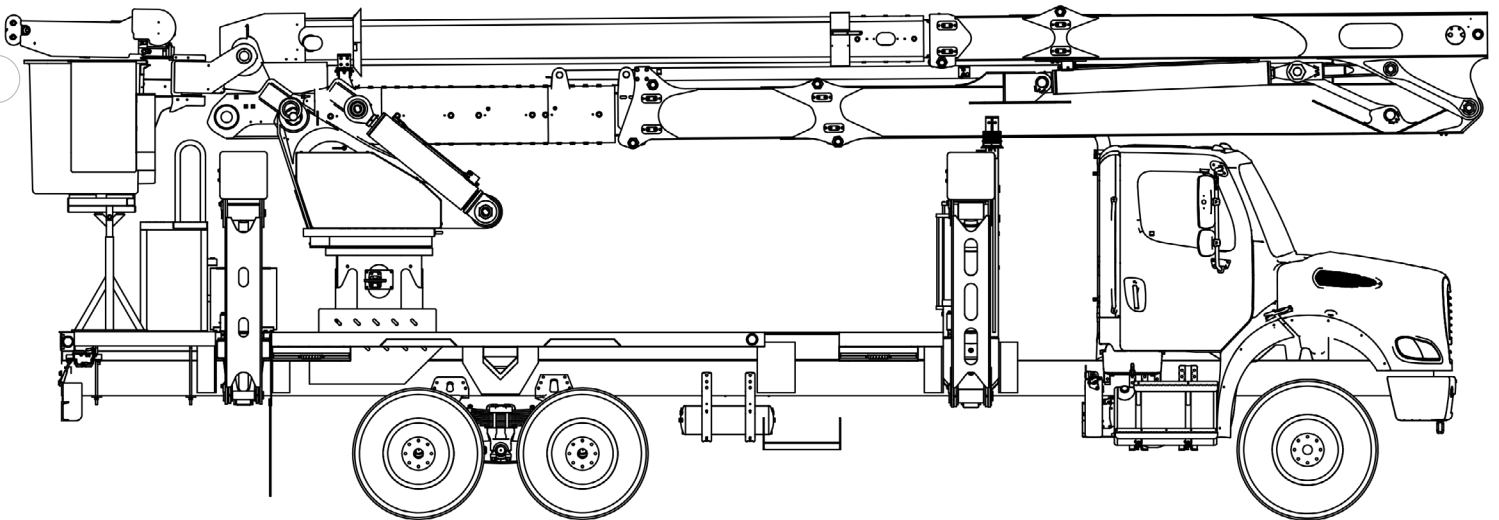

TECH TIPS

TROUBLESHOOTING TM LEVELING WITH GENERATOR STYLE LEVELING

NO. 138



SERVICE CALL:
TROUBLESHOOTING TM LEVELING
WITH GENERATOR STYLE
LEVELING



MODEL(S):
ALL TM END MOUNT PLATFORMS



TOOLS NEEDED:
STANDARD SCREWDRIVER SET
VOLTMETER
1/2" 12 POINT SOCKET OR
WRENCH

TEREX UTILITIES TECHNICAL SUPPORT TEAM

PHONE: 1-844-TEREX4U (1-844-837-3948) | EMAIL: UTILITIES.SERVICE@TEREX.COM

! WARNING



Injection Hazard
Fluid escaping under pressure can penetrate skin and result in death or serious injury.

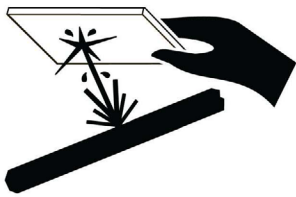

Relieve pressure before disconnecting hydraulic lines.
Stay clear of leaks and pin holes. Use a piece of cardboard or wood to search for leaks. Do not use hand.
Fluid injected into skin must be surgically removed within a few hours by a doctor familiar with this type of injury, or gangrene will result.



DANGER

Failure to obey the instructions and safety rules in the appropriate Operator's Manual and Service Manual for your machine will result in death or serious injury.

Many of the hazards identified in the Operator's Manual are also safety hazards when maintenance and repair procedures are performed.

DO NOT PERFORM MAINTENANCE UNLESS:

- ✓ You are trained and qualified to perform maintenance on this machine.
- ✓ You read, understand and obey:
 - manufacturer's instructions and safety rules
 - employer's safety rules and worksite regulations
 - applicable governmental regulations
- ✓ You have the appropriate tools, lifting equipment and a suitable workshop.

The information contained in this Tech Tip is a supplement to the Service Manual. Consult the appropriate Service Manual of your machine for safety rules and hazards.



TECH TIP 138 | RELEASED 12.11.2023 | VERSION 1.0

©TEREX UTILITIES. ALL RIGHTS RESERVED

CONTENTS

TECH TIP #138

TOC

4

| Check pressures

INTRODUCTION
STEP 1 - STEP 2

5

| Check for platform creep

| Access the controller

STEP 3 - STEP 5

6

| Check fuses and voltage.

STEP 6 - STEP 8

7

| Tilt sensor

STEP 9 - STEP 10

8

| Check the stop valve

STEP 11 - STEP 12

9

| Check canon plug

STEP 13 - STEP 14

10

| Check voltage on canon plug

STEP 15 - STEP 19

11

| Check slope sensor

STEP 20 - STEP 22

13

| Stop valve

STEP 23 - STEP 24

INTRODUCTION

This procedure will help troubleshoot the leveling system on a TM using step-by-step instructions.

STEP 1

Verify that the platform can be manually leveled by enabling the single stick, holding it, and then moving the lever on the Servo valve side-to-side. If the platform leveling works correctly, move on to Step 3. If it does not continue to Step 2.



Do NOT lift the platform leveling control, only operate it from side-to-side. Damage to the control will result.

STEP 2

Consult **Tech Tip #30** for complete information on Checking Pressures on a TM.

The pressure needs to be between 450 to 500 psi to open the pilot valve, allowing oil to reach the servo.

Verify that the level/option valve is in the up position (Top Control Selector) allowing oil to reach the top controls. Also make sure that the E-stop is pulled out at the Top Controls.



STEP 3

Enable the single stick without moving the boom function and observe if the platform remains stationary. If platform moves in one direction or the other, then see **Tech Tip #74** for platform creep. Otherwise continue to Step 4.

STEP 4

Remove the cover for the servo and the leveling control box and open the door for the controller. Check the battery voltage on the leveling. If the voltage is less than 10V, reference **Tech-tip #63** for Troubleshooting the leveling generator, otherwise continue to Step 5.



STEP 5

With the controller door open, slowly move the single stick to operate the upper or lower boom in either direction. The pressure to close the pressure switch comes from the limit valve when running the boom functions up or down. When the pressure switch is closed, the generator will shut off and the controller turns on.

In the upper left-hand corner of the controller, check for a flashing green light that goes out when the generator turns on and operates.

If no light is visible, move to Step 6, otherwise go to Step 7.



STEP 6

Check the fuses and the voltage in the battery. If the fuses are good, then locate the yellow wire hooked to the terminal connector going to the battery. Insert the wire into the middle of the fuse block, then check to see if the light on the controller comes on.

If the light comes on, reference Tech Tip #63 for troubleshooting the pressure switch in the control box.

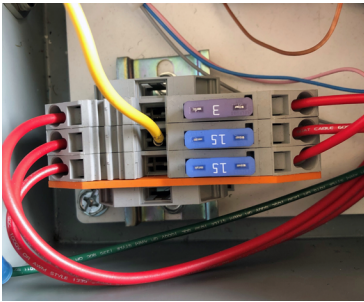

STEP 7

Activate the single stick or lower controls and operate the either boom up or down. Observe whether the platform leveling continues to operate in one direction (not keeping the platform level).

Continue to Step 8 if the platform continues to move in one direction, otherwise jump to Step 11.

STEP 8

Disconnect the tilt wiring harness from the side of the control box labeled Tilt.

Repeat the test from Step 7 again. If the platform keeps moving in the same direction, then go to Step 9.



Otherwise, remove the terminal block off A on the controller and repeat the test again.



STEP 8 (Continued)

If the platform goes out of level, then reconnect Terminal A and remove Terminal block D. If it does not level at all, replace the controller.

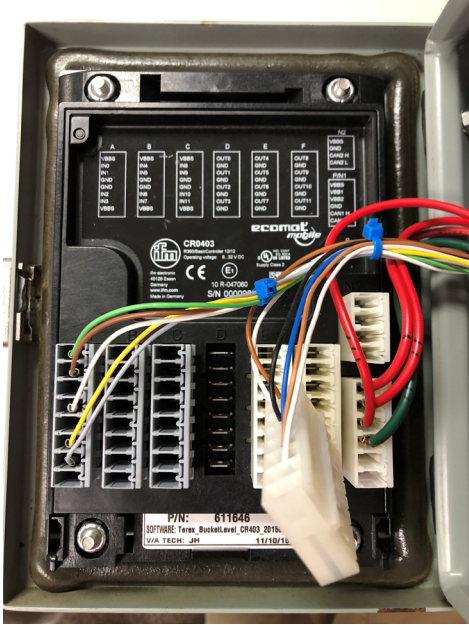

STEP 9

Reconnect the tilt wiring harness to the control box. Next remove the cover off the curbside leveling arm shown below.



Disconnect the wiring harness at the tilt sensor on the curbside leveling arm. Test the leveling again, if the platform starts to level, then replace the tilt wiring harness. Otherwise continue onto Step 10.



STEP 10

If the platform levels in one direction but not the other:

Levels down but not up

- Go to Step 11

Levels up but not down

- Go to Step 15

STEP 11

If the platform levels correctly while operating the upper boom down, but doesn't level when running the upper boom up, start by checking the level up stop valve to make sure it isn't stuck.

The stop valve is located on the street side of the leveling gear box. If the valve is stuck in, repair the valve and retest. Otherwise, continue to Step 12.

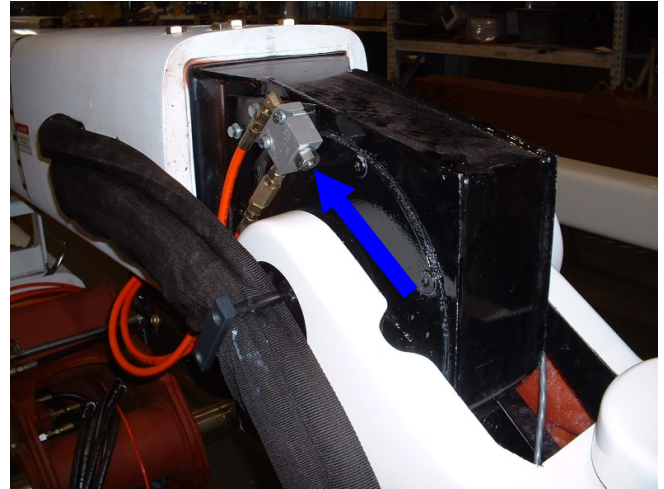

STEP 12

Insert the yellow wire back into the fuse from Step 6. Test for voltage on D1 and D3. Continue to Step 13 if battery voltage is read on both terminals.

If there is no voltage, check the 15 Amp fuse in fuse panel (middle fuse).

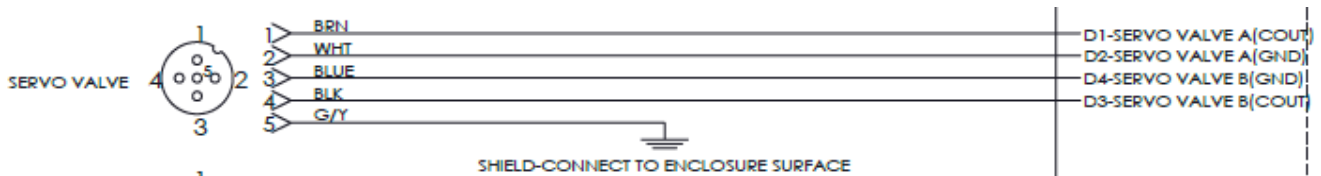
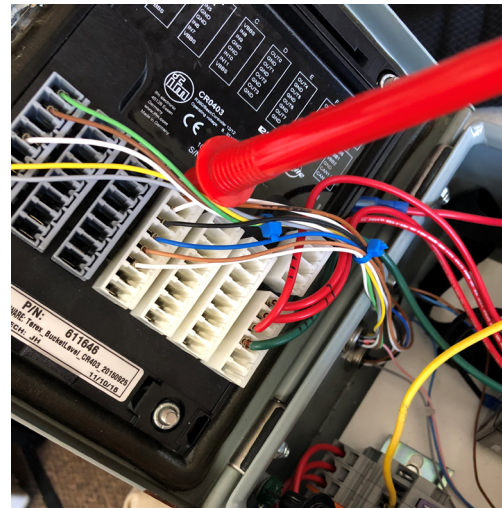
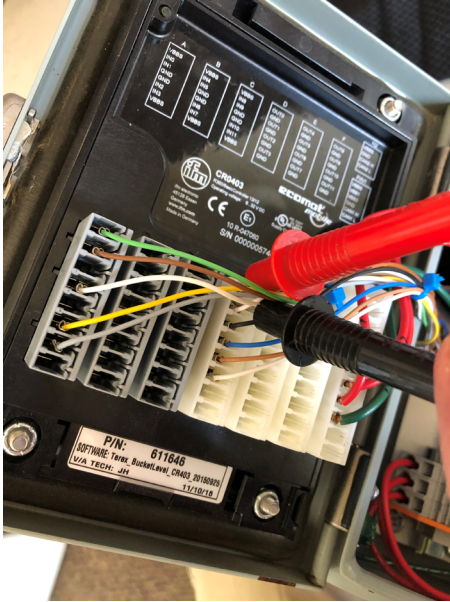

FIGURE 15 - Wiring Schematic Controller to Servo Connector

STEP 13

Tilt the platform in either direction while monitoring the voltage between D1 and D2. Repeat for D3 and D4.



Battery voltage should be on either D1 and D2 or D3 and D4. One will be one direction and the other will be the other direction.

If there is voltage on both connectors, continue on to Step 14. If there is no power on AB or DC, then go to Step 15.

STEP 14

Remove the canon plug on the servo valve and check for continuity between the controller and the canon plug.

If no continuity is present or there is continuity between two wires, then check the wiring and connections.

Also remove the backside of the canon plug to check for broken wires or solder touching connections.

A to Brown, D1 on controller
B to White, D2 on controller
C to Blue, D3 on controller
D to Black, D4 on controller

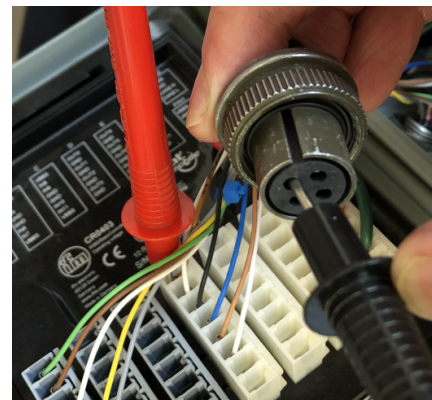
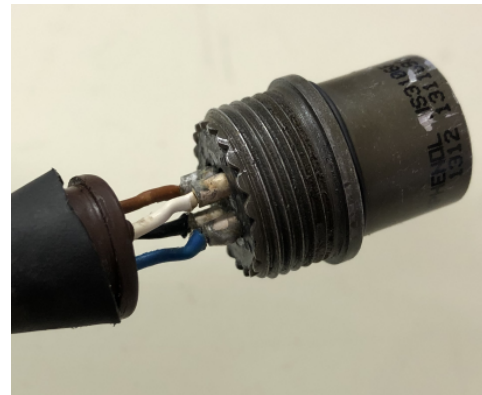

STEP 14 (Continued)

Check voltage at canon plug between A (+) and B (-) or D (+) and C (-) when running boom up or down.

If there is power on both and it still doesn't self level, then replace the servo.



STEP 15

If there is power on either AB or DC and the wiring harness from the tilt switches are good, then Steps 16-22 will verify that the tilt switches are working properly.

STEP 16

Make sure there is battery voltage on the Green wire on A1, this is the voltage going out to the slope sensor and the tilt switches. If no voltage is present, check the 3 Amp fuse in fuse panel.

STEP 17

With a voltmeter, check the wires coming from the tilt sensors for voltage on the yellow and gray wires on A6 and A7

If neither of the wires has any voltage, continue to Step 18. If voltage is present, one of the tilt switches is bad. Yellow is Down (Switch A) and Grey is Up (Switch B).

STEP 18

Remove the tilt sensor assembly from the curbside leveling arm and cut the tie straps. This will bring the tilt sensor assembly closer to the leveling control box.

Note: The platform may need to be rotated to bring it closer.

STEP 19

Place the yellow test wire into the middle of the fuse block to power the controller up.

STEP 20

Put the black lead on the white wire (A4) and red lead on the yellow wire (A6), rotate the basket down (Tilt Switch A) CCW (Counterclockwise) until the top tilt switch is tilted up past horizontal. There should be 12V measured when it is activated.

If voltage is present right away or doesn't ever show voltage, check the wiring harness in between the controller and tilt sensor or tilt switch. Replace wiring harness or tilt switch as needed.



STEP 21

Perform the same procedure with the black lead at the White wire (A4) and the Red lead to the Gray wire (A7). Rotate the basket up (Tilt Switch B) assembly CW (Clockwise) until the bottom tilt switch is tilted up past horizontal. It should show 0V, then 12V when activated above horizontal.

If voltage is present right away or doesn't ever show voltage check wiring harness in between controller and tilt sensor and or tilt switch. Replace wiring harness or tilt switch as needed.

STEP 22

To check the slope sensor, put the red lead to the Brown wire (A2) and the black lead onto the White wire (A4). There should be some voltage present, as it is rotate CCW the voltage will increase. The voltage will decrease when rotated CW.

If no voltage is present, check the wiring harness between controller and tilt sensor assembly.

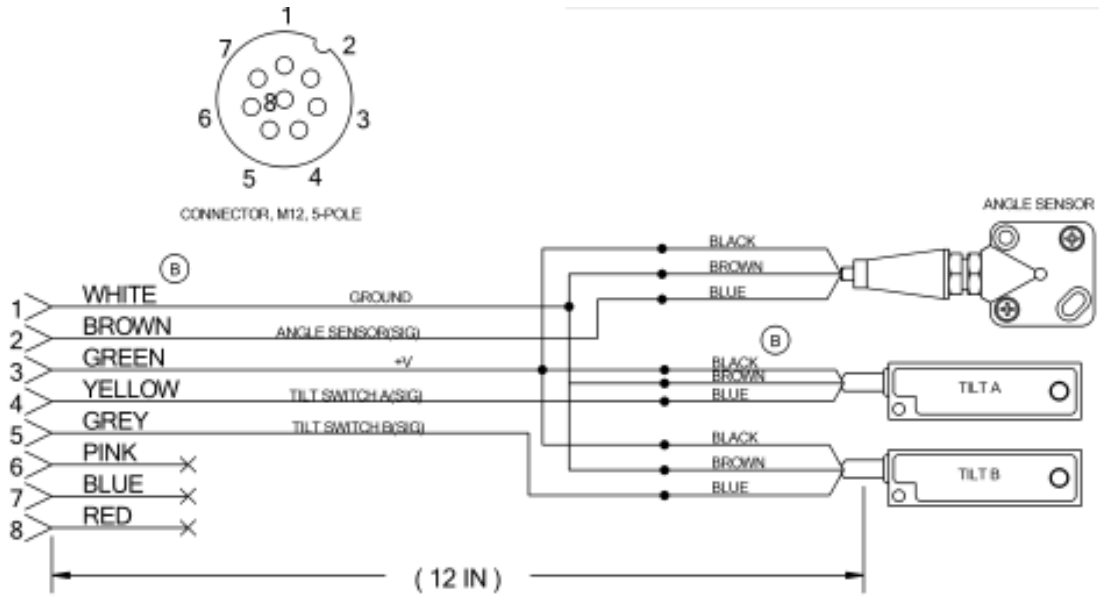

FIGURE 21 - Tilt Sensor Wiring Schematic

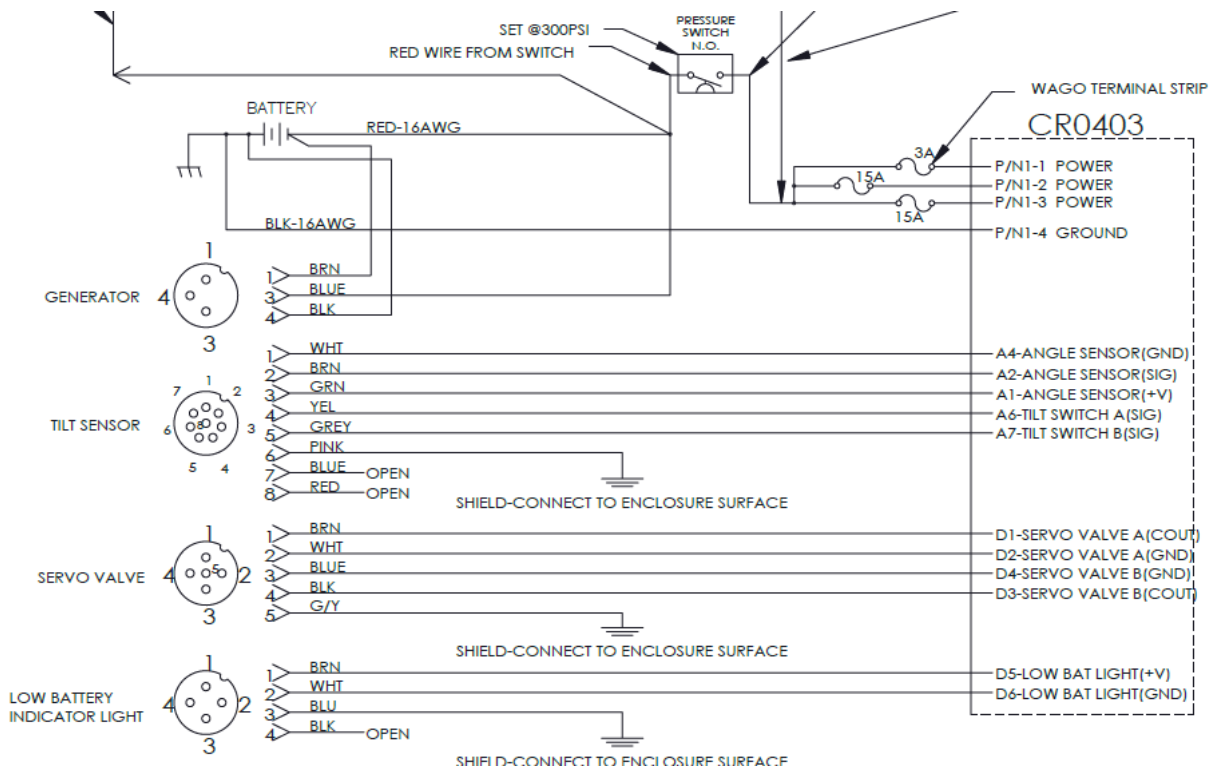

FIGURE 22 - Control Box Wiring Schematic

STEP 23

The pressure from the stop limit system is used to pilot open a pilot valve allowing oil to get to the leveling motor. When the platform rotates and contacts the stop valve located on the curbside of the leveling gear box, the pilot pressure is removed, blocking the level down pressure. To verify that the valve isn't partially stuck, it may require checking the limit system pressure. See **Tech Tip #30** for setting pressures. If this is not the issue, return to Step 12.

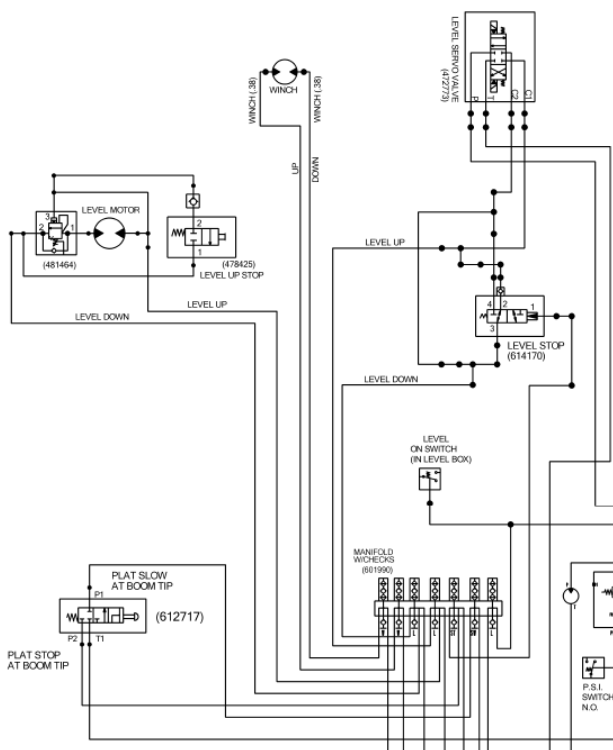
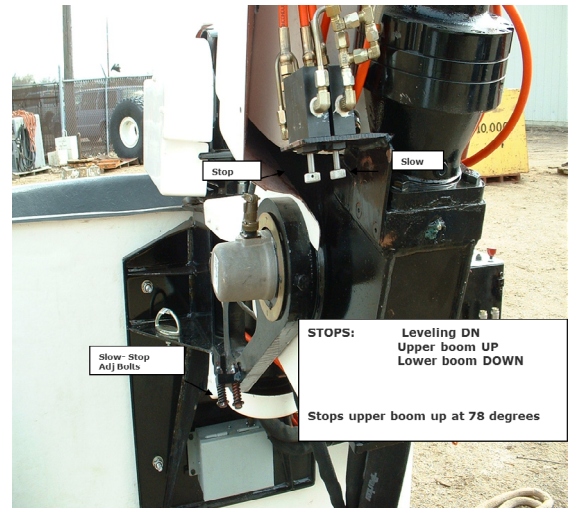

FIGURE 25 - Hydraulic Schematic for Stop

STEP 24

If none of these steps resolve the issue, please contact Terex Utilities Technical Support at 1-844-837-3948 or email utilities.service@terex.com. Please have the unit serial number available.



FOR FURTHER ASSISTANCE,

CONTACT THE TEREX UTILITIES TECHNICAL SUPPORT TEAM

PHONE: [1-844-TEREX4U \(1-844-837-3948\)](tel:1-844-TEREX4U) | EMAIL: UTILITIES.SERVICE@TEREX.COM
