

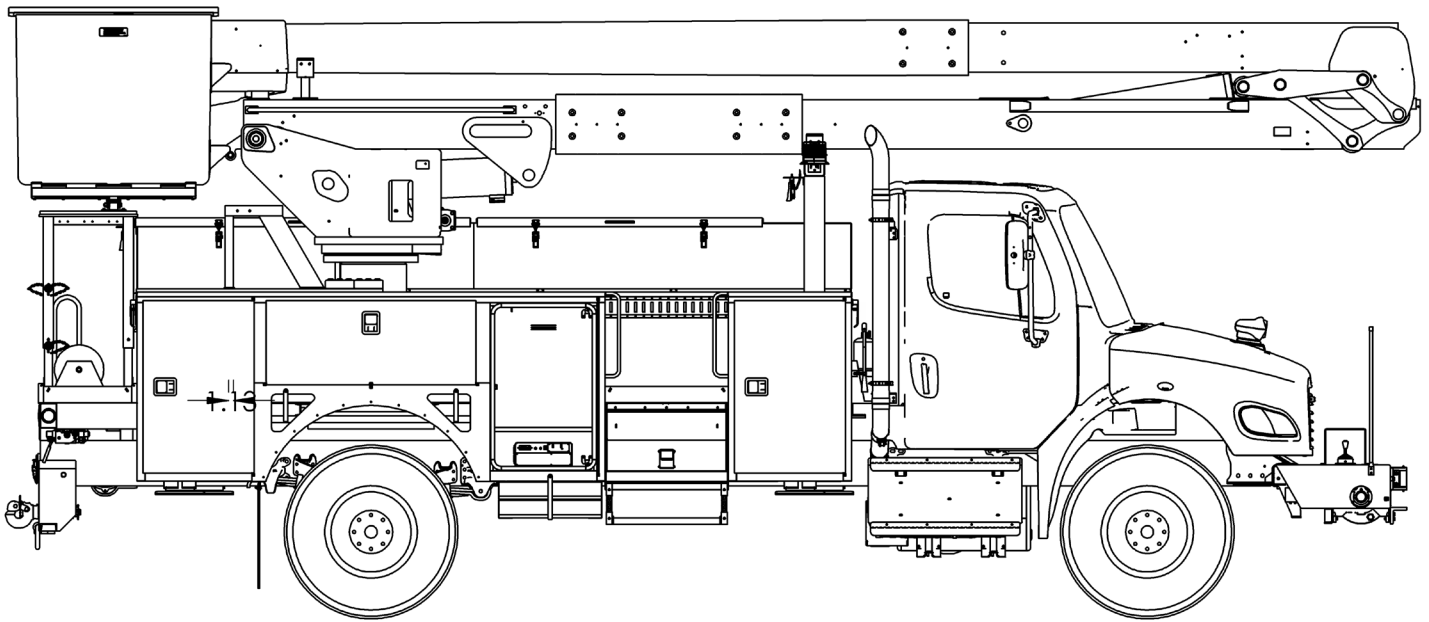

TECH TIPS

REMOVE PARK BRAKE INTERLOCK FOR WORK LIGHTS

NO. 136



SERVICE CALL:
REMOVE PARK BRAKE
INTERLOCK FOR WORK LIGHTS



MODEL(S):
ALL TEREX UTILITIES EQUIPMENT
USING CANVIEW 4 SWITCH
PANEL



TOOLS NEEDED:
NONE

TEREX UTILITIES TECHNICAL SUPPORT TEAM

PHONE: 1-844-TEREX4U (1-844-837-3948) | EMAIL: UTILITIES.SERVICE@TEREX.COM



DANGER

Failure to obey the instructions and safety rules in the appropriate Operator's Manual and Service Manual for your machine will result in death or serious injury.

Many of the hazards identified in the Operator's Manual are also safety hazards when maintenance and repair procedures are performed.

DO NOT PERFORM MAINTENANCE UNLESS:

- ✓ You are trained and qualified to perform maintenance on this machine.
- ✓ You read, understand and obey:
 - manufacturer's instructions and safety rules
 - employer's safety rules and worksite regulations
 - applicable governmental regulations
- ✓ You have the appropriate tools, lifting equipment and a suitable workshop.

The information contained in this Tech Tip is a supplement to the Service Manual. Consult the appropriate Service Manual of your machine for safety rules and hazards.



TECH TIP 136 | RELEASED 12.11.2023 | VERSION 1.0
©TEREX UTILITIES. ALL RIGHTS RESERVED

CONTENTS

TECH TIP#136

TOC

4

| *Version 2.5.4.0 and older*

**INTRODUCTION
STEP 1 - STEP 3**

5

| *Version 2.5.4.1 and newer*

STEP 4 - STEP 7

6

| *Button labels*

STEP 8 - STEP 10

INTRODUCTION

Use **Tech Tip 117** to determine the software version used on the panel.

If the version is prior to 2.5.4.1, only follow steps 1-5.

For software version 2.5.4.1 and newer, jump to Step 6.

STEP 1 - Version 2.5.4.0 and older

Press the “Home/Select” button until “Settings” appears on the right-hand side of the screen. Press the “Settings” button.

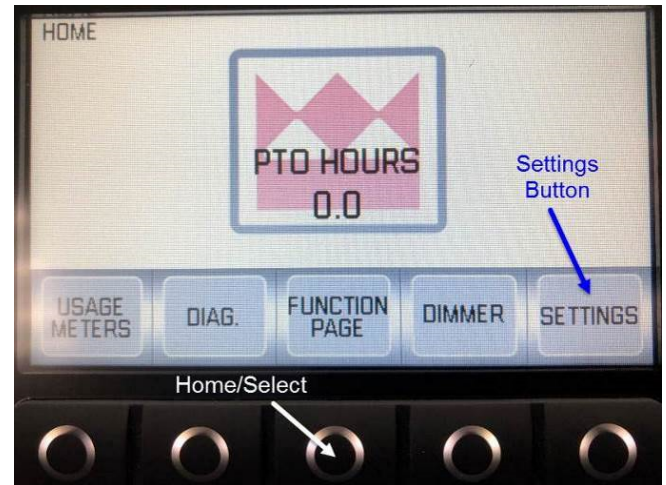

STEP 2

Scroll through “Settings” until “Control Settings” is available. Once highlighted, press the “Select” button.



STEP 3

Scroll through “Control Settings” until “Work Lights” is available. Once highlighted, press the “Select” button.

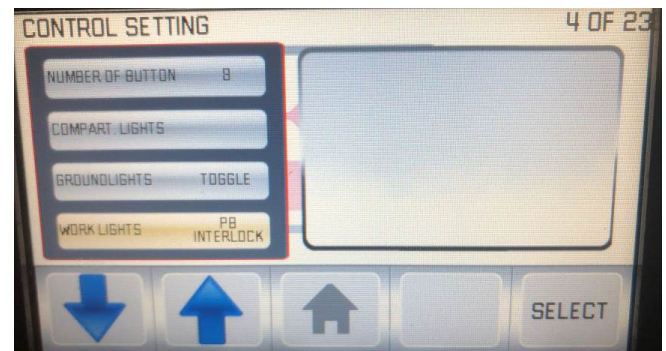

STEP 4

Options will appear in the box on the right. Scroll through until "Toggle" is displayed. Press the "Select" button.



STEP 5

Press the "home/select" button until the "Function" screen is shown again. Test the work light functionality to verify it is working without engaging the park brake ON.

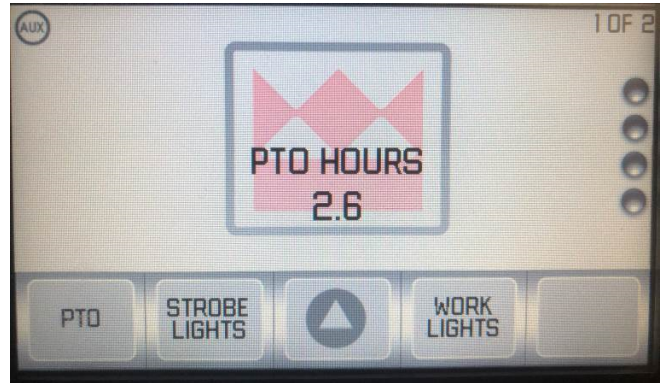

STEP 6 - Version 2.5.4.1 and newer

Press the "Home/Select" button until "Settings" appears on the right-hand side of the screen. Press the "Settings" button.

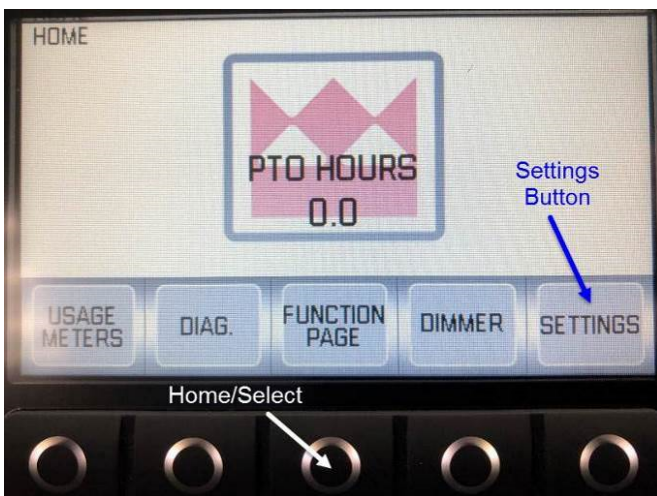

STEP 7

Scroll through "Settings" until "Button Labels" is available. Once highlighted, press the "Select" button.



STEP 8

Scroll through “Button Labels” until “Work Lights” is available. Once highlighted, press the “Behavior” button.

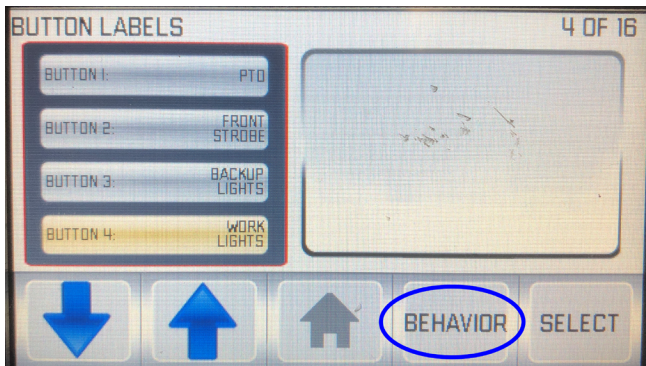

STEP 9

Scroll through “Button Labels” until “Work Lights” is available. Once highlighted, press the “Behavior” button.



STEP 10

Press “Back” and then the “Home/Select”. Test the work light functionality to verify it is working without engaging the park brake ON.

STEP 11

Note: Not all units have programming capability. If you have any questions, please contact Terex Utilities Technical Support at 1-844-Terex4U (1-844-837-3948) or utilities.service@terex.com.



FOR FURTHER ASSISTANCE,
CONTACT THE TEREX UTILITIES TECHNICAL SUPPORT TEAM
PHONE: **1-844-TEREX4U (1-844-837-3948)** | EMAIL: **UTILITIES.SERVICE@TEREX.COM**
