

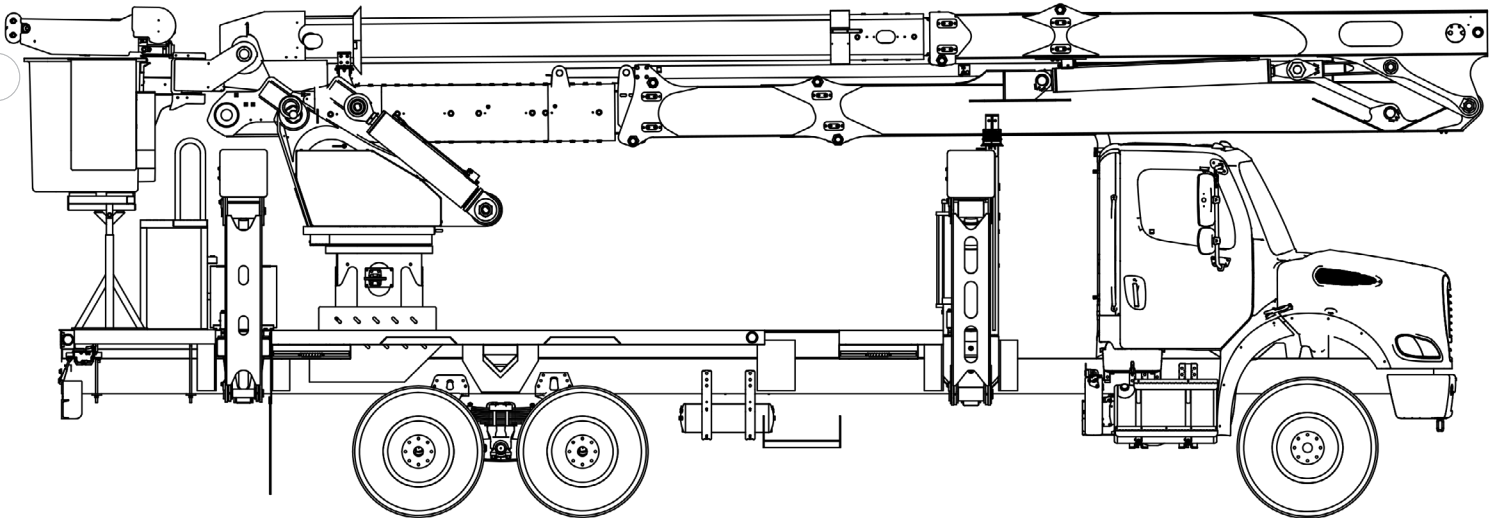

TECH TIPS

TM WEAR PAD ADJUSTMENT

NO. 134



SERVICE CALL:
TM WEAR PAD ADJUSTMENT



MODEL(S):
TM MODELS WITH END MOUNT
PLATFORMS



TOOLS NEEDED:
9/16" WRENCH OR SOCKET
1/4" ALLEN WRENCH
TAPE MEASURE
BLUE LOCTITE
GREASE LITHIUM BASE EP#2

TEREX UTILITIES TECHNICAL SUPPORT TEAM

PHONE: 1-844-TEREX4U (1-844-837-3948) | EMAIL: UTILITIES.SERVICE@TEREX.COM



DANGER

Failure to obey the instructions and safety rules in the appropriate Operator's Manual and Service Manual for your machine will result in death or serious injury.

Many of the hazards identified in the Operator's Manual are also safety hazards when maintenance and repair procedures are performed.

DO NOT PERFORM MAINTENANCE UNLESS:

- ✓ You are trained and qualified to perform maintenance on this machine.
- ✓ You read, understand and obey:
 - manufacturer's instructions and safety rules
 - employer's safety rules and worksite regulations
 - applicable governmental regulations
- ✓ You have the appropriate tools, lifting equipment and a suitable workshop.

The information contained in this Tech Tip is a supplement to the Service Manual. Consult the appropriate Service Manual of your machine for safety rules and hazards.



TECH TIP 134 | RELEASED 12.22.2023 | VERSION 1.0
©TEREX UTILITIES. ALL RIGHTS RESERVED

CONTENTS

TECH TIP #134

TOC

4

| Center the inner boom over the rollers
| Add or remove shims

STEP 1 - STEP 3

5

| Apply loctite
| Install wear pad assembly
| Test operation

STEP 4 - STEP 7

STEP 1

Position the unit with the booms in the stored position and the engine OFF, check the rollers on the upper and lower booms for proper installation and adjustment per the unit specific maintenance manual and **Tech Tip #121**.

STEP 2

Starting at the 4 wear pads at the end of the outer boom, center the inner boom sidewalls over the rollers, measure the gap from the inner boom and the outside of the outer boom.

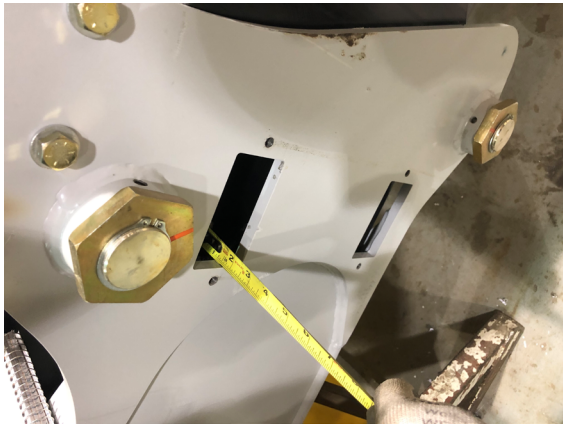

STEP 3

Add or remove shims under the wear pads and pad weldments on each side of the inner boom. To ensure that the inner boom sidewalls travel over the center of the rollers. The total gap cannot be greater than 1/16" between wear pads and inner boom.

Note: The rollers must be positioned under the side plates of the boom to allow the side plates to support the weight. Failure to do so can cause damage to the bottom plate of the inner boom.



STEP 4

When the wear pad is shimmed to the desired dimension, apply blue loctite to the threads of the 5/16" countersunk fastener and torque to a standard torque value of 20 ft-lbs.



STEP 5

Before installing the wear pad assemblies, note the orientation of the beveled edge of the wear pad. This bevel allows clearance for the welds on the lower extension boom.

On the lower boom:

- The top 4 wear pads are installed with the bevel up.
- The 4 bottom wear pads are installed with the bevel down.

The wear pads on the upper boom provide clearance for the upper extension boom bulkhead access covers.

On the upper boom:

- At the end of the upper elbow weldment the top 2 wear pads are installed with the bevel down and the bottom 2 wear pads have the bevel up
- At the elbow side, the top 2 wear pads are installed with the bevel up and the 2 bottom wear pads have the bevel down

STEP 6

Install the wear pad assembly with grease applied to the wear pad. Use blue loctite on the threads of the fasteners and torque to a standard torque of 23 ft-lbs.

STEP 7

Set the unit up for operation with the outriggers properly deployed. Operate the upper and lower boom extend and retract functions, checking for excessive wear pad and roller drag. Re-adjust the wear pads if necessary so the boom is centered on the rollers.

If you have any questions, please contact Terex Utilities Technical Support at 1-844-Terex4U (1-844-837-3948) or utilities.service@terex.com.



FOR FURTHER ASSISTANCE,

CONTACT THE TEREX UTILITIES TECHNICAL SUPPORT TEAM

PHONE: [1-844-TEREX4U \(1-844-837-3948\)](tel:1-844-TEREX4U) | EMAIL: UTILITIES.SERVICE@TEREX.COM
