

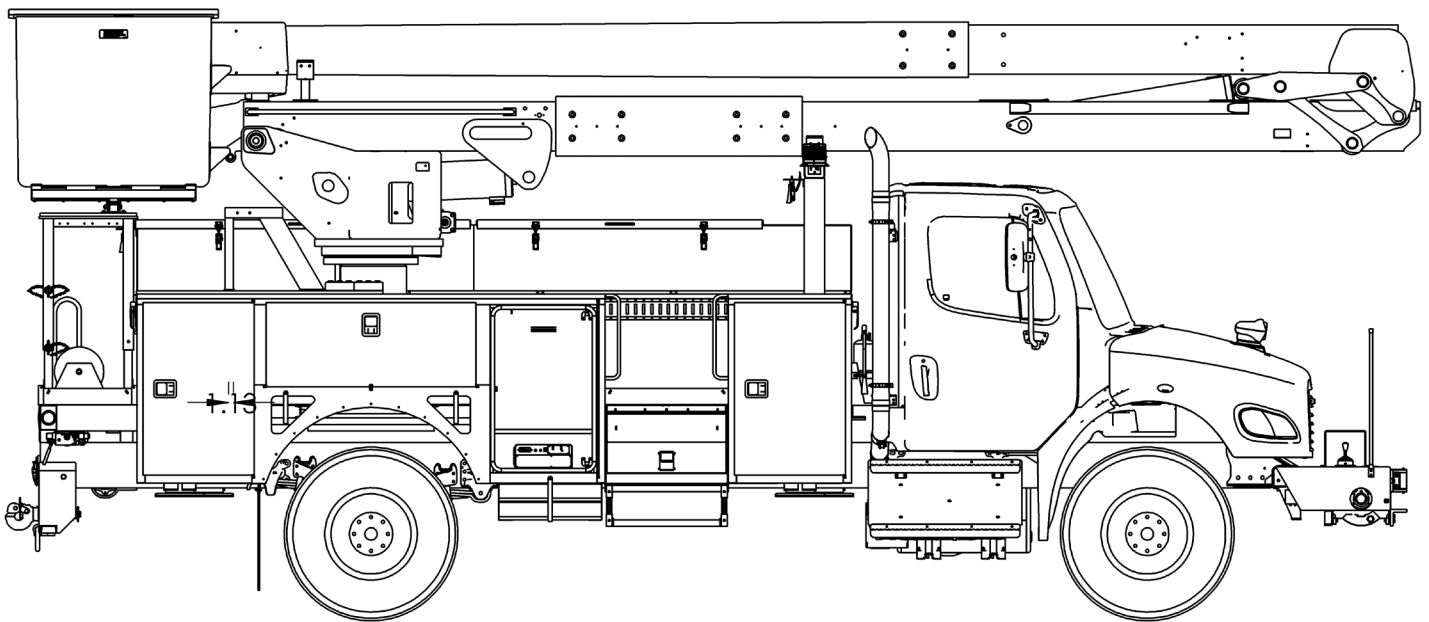

TECH TIPS

IMPORT/EXPORT CONFIGURATION FILE

NO. 131



SERVICE CALL:
IMPORT/EXPORT CONFIGURATION
FILE



MODEL(S):
TEREX UTILITIES EQUIPMENT
USING A CANVIEW 4 SWITCH
PANEL



TOOLS NEEDED:
FLASH DRIVE

TEREX UTILITIES TECHNICAL SUPPORT TEAM

PHONE: 1-844-TEREX4U (1-844-837-3948) | EMAIL: UTILITIES.SERVICE@TEREX.COM



DANGER

Failure to obey the instructions and safety rules in the appropriate Operator's Manual and Service Manual for your machine will result in death or serious injury.

Many of the hazards identified in the Operator's Manual are also safety hazards when maintenance and repair procedures are performed.

DO NOT PERFORM MAINTENANCE UNLESS:

- ✓ You are trained and qualified to perform maintenance on this machine.
- ✓ You read, understand and obey:
 - manufacturer's instructions and safety rules
 - employer's safety rules and worksite regulations
 - applicable governmental regulations
- ✓ You have the appropriate tools, lifting equipment and a suitable workshop.

The information contained in this Tech Tip is a supplement to the Service Manual. Consult the appropriate Service Manual of your machine for safety rules and hazards.



TECH TIP 131 | RELEASED 12.01.2023 | VERSION 1.0
©TEREX UTILITIES. ALL RIGHTS RESERVED

CONTENTS

TECH TIP#131

TOC

4

| *Exporting the configuration file*

INTRODUCTION
STEP 1 - STEP 4

5

| *Importing the configuration file*

STEP 5 - STEP 6
STEP 1 - STEP 2

6

| *Import configuration and verify*

STEP 3 - STEP 6

INTRODUCTION

Not all Canview 4 switch panels have this ability to be programmed. Do not install any software without prior approval from Terex Utilities.

If you have any questions, contact Terex Utilities Technical Support at 1-844-Terex4U (1-844-837-3948) or utilities.service@terex.com.

Exporting the Configuration File

STEP 1

Turn the ignition key ON and allow the screen to fully boot up.

STEP 2

Follow the wires from the back of the switch panel and locate the USB port. It should have a red dust cap on it. Remove the cap and insert the Flash drive.

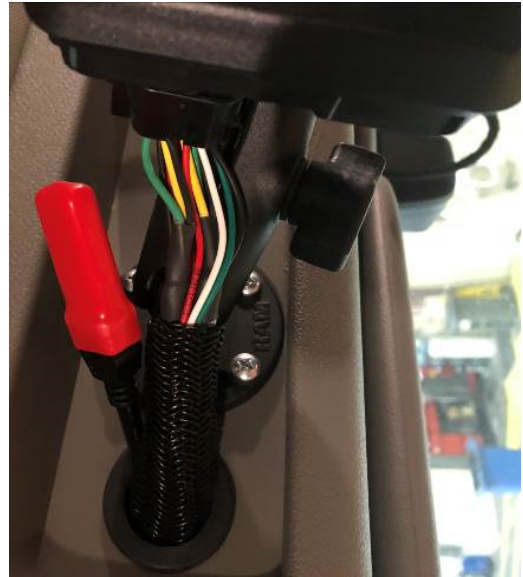

STEP 3

Press the “Home/Select” button until “Settings” appears on the right-hand side of the screen. Press the “Settings” button.



STEP 4

Scroll through “Settings” until “Configuration Page” is available. Once highlighted, press the “Select” button.



STEP 5

Press “Print Config”, the light will flash green if the file is saved to the USB drive. If the light is red, try power cycling the screen or switch to a new flash drive.



STEP 6

Confirm that the file is saved on the flash drive.



Importing the Configuration File

STEP 1

Install the unit specific configuration file on an empty flash drive.



STEP 2

Press the “Home/Select” button until “Settings” appears on the right-hand side of the screen. Press the “Settings” button.



STEP 3

Scroll through “Settings” until “Configuration Page” is available. Once highlighted, press the “Select” button.



STEP 4

Press the “Import Config” button once.

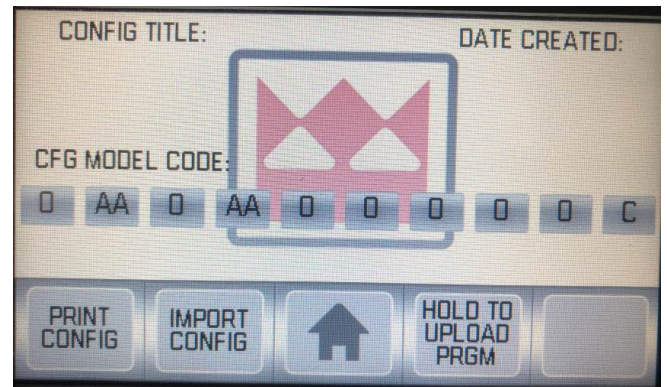

STEP 5

Confirm the Config Title is correct. If correct press CONFIRM CONFIG and that will apply the config file.

Note: If you have any questions, contact Terex Utilities Technical Support at 1-844-Terex4U (1-844-837-3948) or utilities.service@terex.com

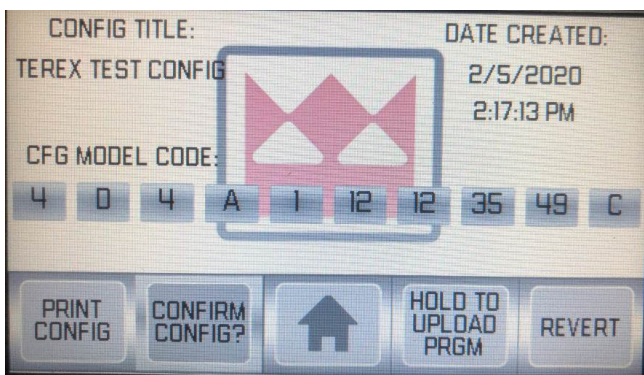

STEP 6

Verify inputs, outputs, and button labels to verify everything is correct. Operate the unit through the full range of functions.



FOR FURTHER ASSISTANCE,
CONTACT THE TEREX UTILITIES TECHNICAL SUPPORT TEAM
PHONE: **1-844-TEREX4U (1-844-837-3948)** | EMAIL: **UTILITIES.SERVICE@TEREX.COM**
