

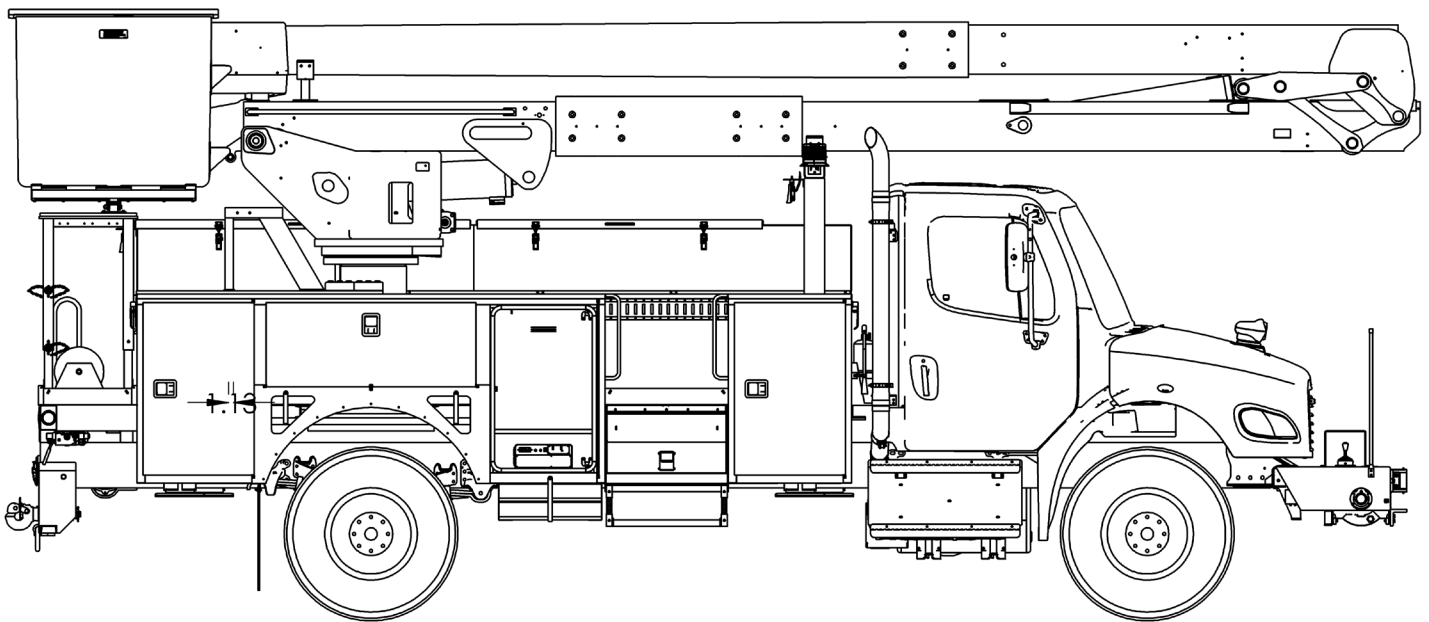

# TECH TIPS

## NO. 130

### UPDATING SOFTWARE ON CANVIEW 4



**SERVICE CALL:**  
UPDATING SOFTWARE ON  
CANVIEW 4



**MODEL(S):**  
ALL TEREX UTILITIES EQUIPMENT  
USING CANVIEW 4 SWITCH  
PANELS



**TOOLS NEEDED:**  
USB FLASH DRIVE

TEREX UTILITIES TECHNICAL SUPPORT TEAM

PHONE: 1-844-TEREX4U (1-844-837-3948) | EMAIL: [UTILITIES.SERVICE@TEREX.COM](mailto:UTILITIES.SERVICE@TEREX.COM)



## **DANGER**

Failure to obey the instructions and safety rules in the appropriate Operator's Manual and Service Manual for your machine will result in death or serious injury.

Many of the hazards identified in the Operator's Manual are also safety hazards when maintenance and repair procedures are performed.

## **DO NOT PERFORM MAINTENANCE UNLESS:**

- ✓ You are trained and qualified to perform maintenance on this machine.
- ✓ You read, understand and obey:
  - manufacturer's instructions and safety rules
  - employer's safety rules and worksite regulations
  - applicable governmental regulations
- ✓ You have the appropriate tools, lifting equipment and a suitable workshop.

The information contained in this Tech Tip is a supplement to the Service Manual. Consult the appropriate Service Manual of your machine for safety rules and hazards.



TECH TIP 130 | RELEASED 12.07.2023 | VERSION 1.0  
©TEREX UTILITIES. ALL RIGHTS RESERVED

# CONTENTS

## TECH TIP #130

4

| *Locate the USB port*

| *Determine software version*

**INTRODUCTION**  
**STEP 1 - STEP 3**

5

| *Software less than 2.3.0.*

**STEP 1 - STEP 3**

6

| *Software 2.3.0 and above*

**STEP 1 - STEP 4**

7

| *Updating from a lower version to 2.6.3.3 or higher*

**STEP 1 - STEP 5**

## INTRODUCTION

Not all Canview 4 switch panels have the ability to be programmed. Do not install any software without prior approval from Terex Utilities.

**Note:** Depending on the age of the unit, there are three ways the software will be installed.

**Note:** The update process can take from a few seconds to over 10 minutes to complete.

If you have any questions, contact Terex Utilities Technical Support at 1-844-Terex4U (1- 844-837-3948) or [utilities.service@terex.com](mailto:utilities.service@terex.com).

## STEP 1

Copy the software onto a blank USB flash drive. An example of the file is shown below.



## STEP 2

Follow the wires from the back of the switch panel and locate the USB port. It should have a red dust cap covering it.



## STEP 3

Determine the software version currently installed using Tech-tip 117 as a reference.

**Note:** When updating from an older version of software to 2.6.3.3 or higher, additional steps are required.

**Software versions less than 2.3.0**

**Software versions between 2.3.0 and 2.6.3.2**

**Upgrading from software version 2.6.3.2 and lower to 2.6.3.3 and above**



## Software versions less than 2.3.0

### STEP 1

Remove the cap and insert the flash drive into the port. Disconnect power by removing the connector on the back of the switch panel.



### STEP 2

Push down buttons 2 and 4 at the same time. Continue holding these buttons while reconnecting the connector from Step 1.

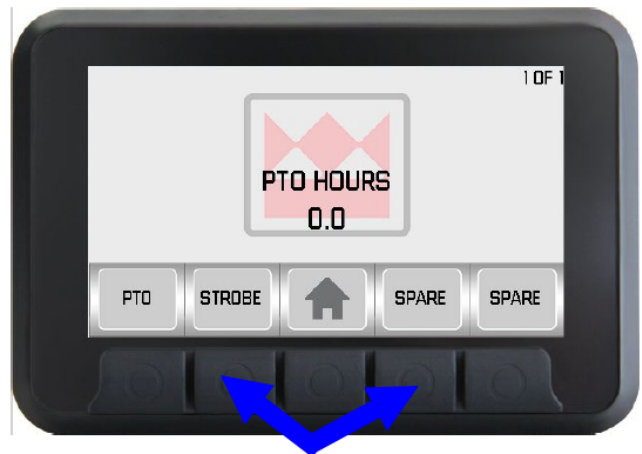

### STEP 3

After the black screen is displayed, a prompt will appear to update the application. Push YES to continue.

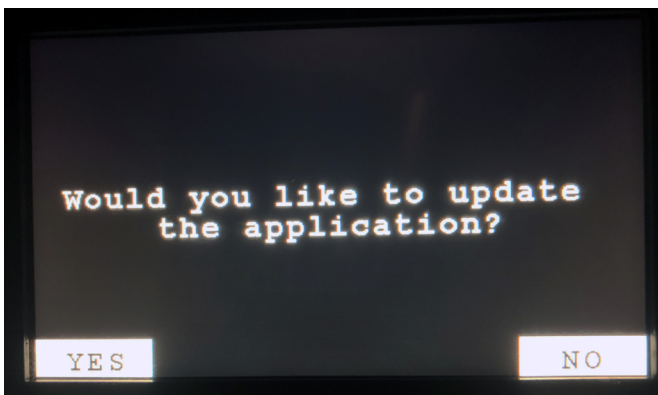

## Software versions 2.3.0 and above

### STEP 1

Remove the cap and insert the flash drive into the port. Press the “Home/Select” button until the “Settings” option appears on the right-hand side of the screen. Press “Settings” to continue.



### STEP 2

Scroll through “Settings” until “Configure Page” is available. Once highlighted, press the “Select” button.

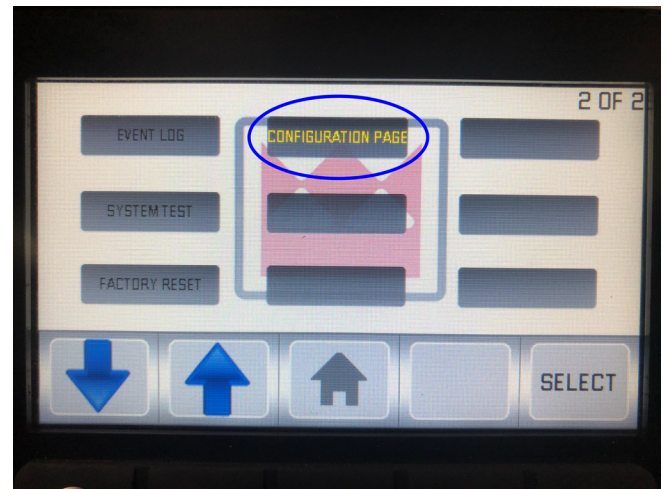

### STEP 3

Press and hold the button labeled “Hold to Upload Prgm” until the screen goes black.

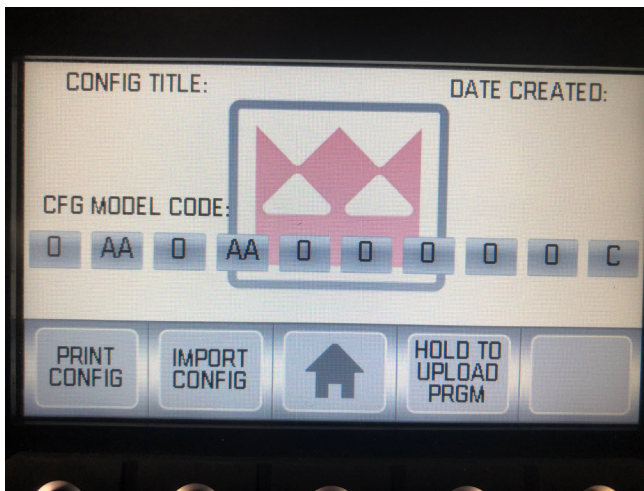

### STEP 4

After the black screen is displayed, a prompt will appear to update the application. Push YES to continue.

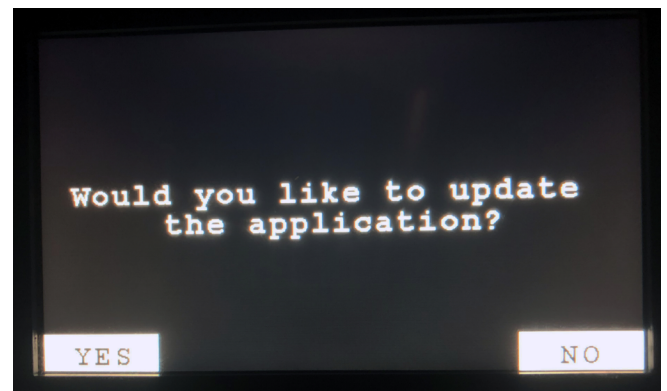



## Upgrading from a lower software version to 2.6.3.3 or higher

### STEP 1

Press the home button, then press the settings button on the home page.



### STEP 2

Use the up or down arrow button to navigate to the Configuration page, then press Select.



### STEP 3

With the configuration page displayed, put the thumb drive in the USB port and press "Print Config" to export the current configuration.

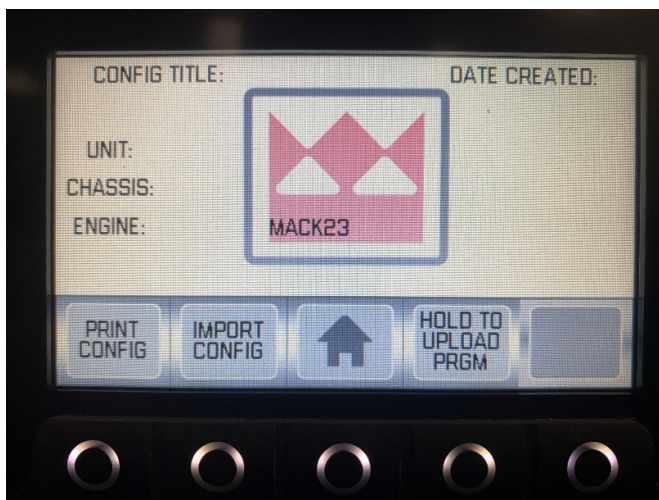

### STEP 4

If the configuration is exported successfully, the Print Config button will turn green. Press and hold the "Hold to Upload Prgm" button to load the new program.

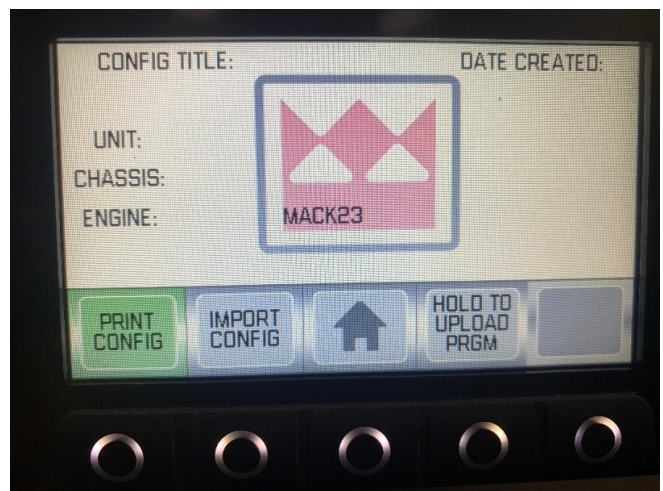

## STEP 5

When the screen comes back on after re-programming, navigate back to “Configuration” page and press the “Import Config” button. The button will darken, then press the “Import Config” button again to import the configuration.



FOR FURTHER ASSISTANCE,  
CONTACT THE TEREX UTILITIES TECHNICAL SUPPORT TEAM  
PHONE: **1-844-TEREX4U (1-844-837-3948)** | EMAIL: **[UTILITIES.SERVICE@TEREX.COM](mailto:UTILITIES.SERVICE@TEREX.COM)**

---