

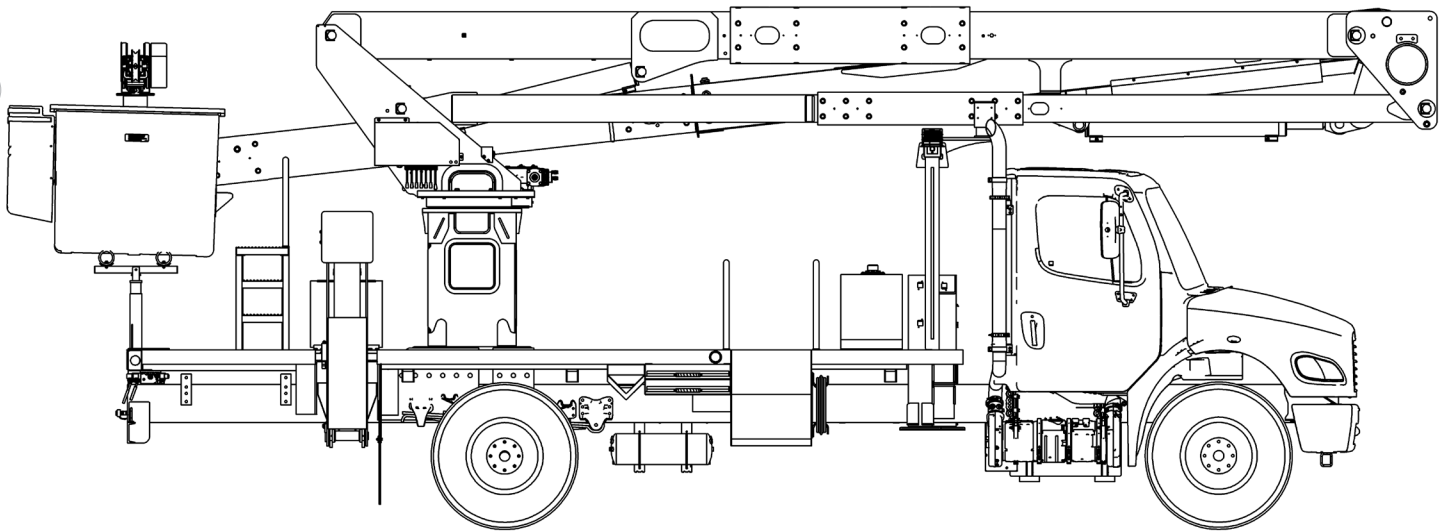

# TECH TIPS

SWITCHING BUTTONS ON THE CANVIEW 4 SWITCH PANEL

NO. 125



**SERVICE CALL:**  
SWITCHING BUTTONS ON THE  
CANVIEW 4 SWITCH PANEL



**MODEL(S):**  
ALL TEREX UTILITIES EQUIPMENT  
USING THE CANVIEW 4 SWITCH  
PANEL



**TOOLS NEEDED:**  
ELECTRICAL SCHEMATIC

TEREX UTILITIES TECHNICAL SUPPORT TEAM

PHONE: 1-844-TEREX4U (1-844-837-3948) | EMAIL: [UTILITIES.SERVICE@TEREX.COM](mailto:UTILITIES.SERVICE@TEREX.COM)



## **DANGER**

Failure to obey the instructions and safety rules in the appropriate Operator's Manual and Service Manual for your machine will result in death or serious injury.

Many of the hazards identified in the Operator's Manual are also safety hazards when maintenance and repair procedures are performed.

## **DO NOT PERFORM MAINTENANCE UNLESS:**

- ✓ You are trained and qualified to perform maintenance on this machine.
- ✓ You read, understand and obey:
  - manufacturer's instructions and safety rules
  - employer's safety rules and worksite regulations
  - applicable governmental regulations
- ✓ You have the appropriate tools, lifting equipment and a suitable workshop.

The information contained in this Tech Tip is a supplement to the Service Manual. Consult the appropriate Service Manual of your machine for safety rules and hazards.



TECH TIP 125 | RELEASED 12.08.2023 | VERSION 1.0  
©TEREX UTILITIES. ALL RIGHTS RESERVED

# CONTENTS

## TECH TIP #125

### TOC

4 | *Open settings*  
**STEP 1 - STEP 3**

5 | *Switch buttons*  
**STEP 4 - STEP 6**

6 | *Change outputs*  
**STEP 7 - STEP 8**

7 | *Verify settings*  
**STEP 9**

## STEP 1

Determine which two buttons need to be changed. In this example Button 2 and 3 will be switched (Strobe Lights and Compartment Lights).

**Note:** Button 1 is the only button that cannot be changed. PTO will always be the first button.

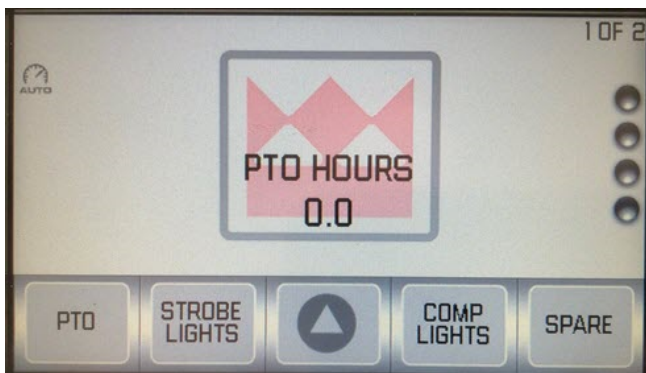

## STEP 2

Press the middle button on the display until Settings are displayed. If Settings is not available, this version of the Switch Panel does not support programming by the user.



## STEP 2 (Continued)

Click on Settings to continue.

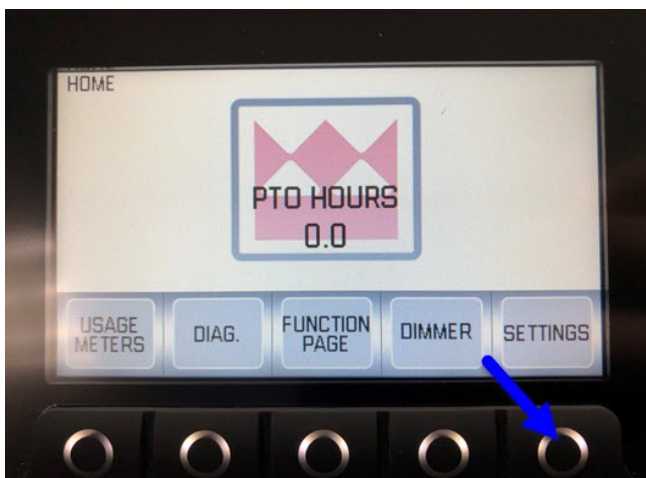

## STEP 3

Use the up/down arrows to select Button Labels. Once it is highlighted, push the select button.



## STEP 4

Use the up/down arrows to highlight the button that needs to be switched. For this example, highlight Button 2, then use the up/down arrows to change Strobe Lights to Compartment Lights. Press the Select button to save the changes.

## STEP 5

Use up/down buttons to highlight Button 3. Press the Select button and use the up/down buttons until Strobe Lights are selected as the option. Press the Select button to save the changes.

## STEP 6

Press the Home button to return to the Settings screen. Below is the before and after of the button changes.

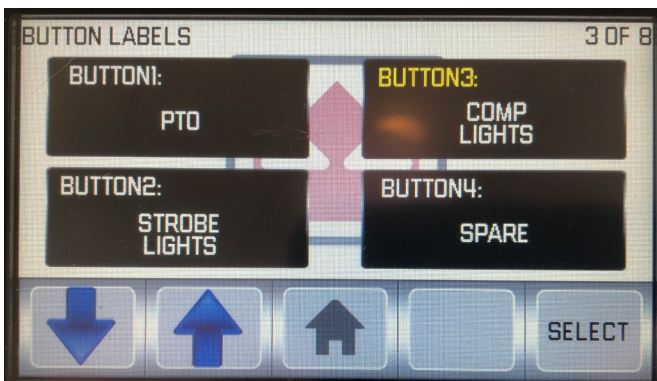
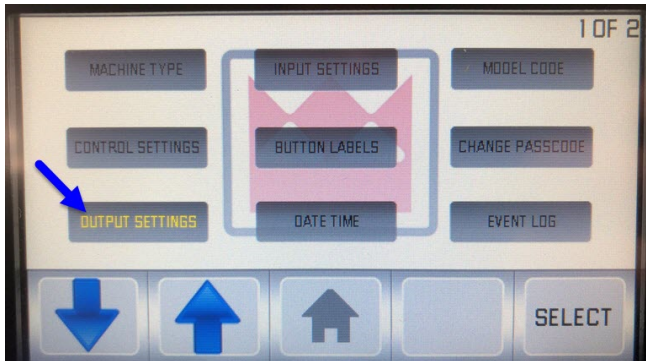

FIGURE 5 - Before

FIGURE 6 - After

## STEP 7

Use the up/down buttons to highlight output settings. Once it is highlight press the select button.



## STEP 8

In this example, the original output for Strobe Lights is K6 and Compartment Lights is K7. To change this, use the up/down buttons to highlight the output that needs to be changed. Press the Select button and use the up/down buttons until the box on the right matches the new output. The pictures below are the before and after.

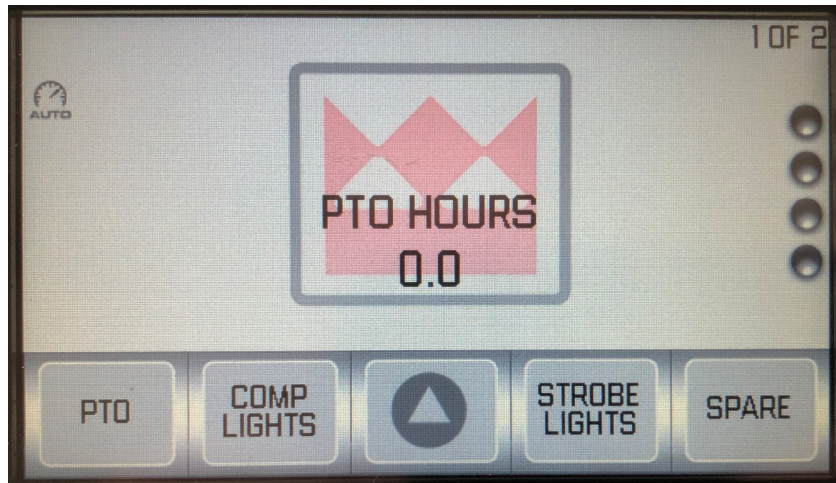

FIGURE 8 - Before

FIGURE 9 - After

## STEP 9

Press the Home button and test out the functionality of the changed buttons to confirm proper operation.



**Note:** Not all Canview 4 switch panels have this ability. If you have any questions, contact Terex Utilities Technical Support at 1-844-Terex4U (1-844-837-3948) or [utilities.service@terex.com](mailto:utilities.service@terex.com)

**Note:** Any changes made after factory installation should be noted in the electrical schematic provided with the unit. Contact Terex Utilities Technical Support at 1-844-Terex4U (1-844-837-3948) or [utilities.service@terex.com](mailto:utilities.service@terex.com) to notify us about the change. Keeping our files up-to-date will enable the correct program to be loaded if a replacement switch panel is ordered in the future.



FOR FURTHER ASSISTANCE,

CONTACT THE TEREX UTILITIES TECHNICAL SUPPORT TEAM

PHONE: [1-844-TEREX4U \(1-844-837-3948\)](tel:1-844-TEREX4U) | EMAIL: [UTILITIES.SERVICE@TEREX.COM](mailto:UTILITIES.SERVICE@TEREX.COM)

---