

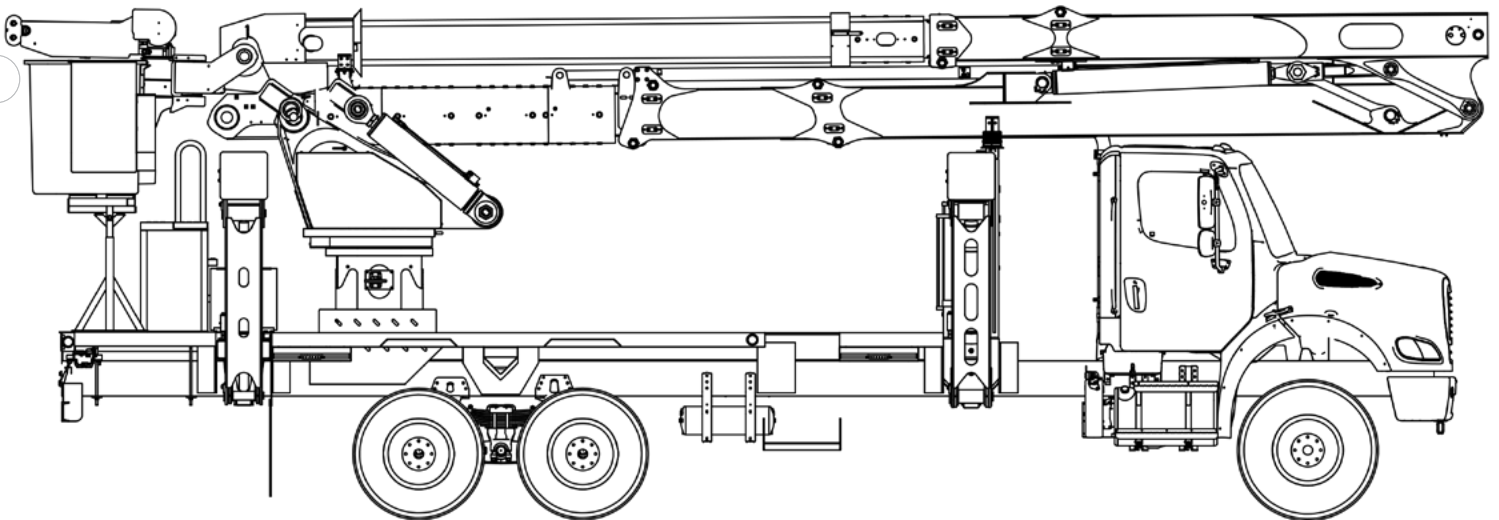

TECH TIPS

HOW TO USE THE MANUAL LETDOWN ON THE TM SERIES

NO. 57



SERVICE CALL:
HOW TO USE THE MANUAL
LETDOWN



MODEL(S):
TM SERIES



TOOLS NEEDED:
7/8" WRENCH
JACK HANDLE

TEREX UTILITIES TECHNICAL SUPPORT TEAM

PHONE: 1-844-TEREX4U (1-844-837-3948) | EMAIL: UTILITIES.SERVICE@TEREX.COM



DANGER

Failure to obey the instructions and safety rules in the appropriate Operator's Manual and Service Manual for your machine will result in death or serious injury.

Many of the hazards identified in the Operator's Manual are also safety hazards when maintenance and repair procedures are performed.

DO NOT PERFORM MAINTENANCE UNLESS:

- ✓ You are trained and qualified to perform maintenance on this machine.
- ✓ You read, understand and obey:
 - manufacturer's instructions and safety rules
 - employer's safety rules and worksite regulations
 - applicable governmental regulations
- ✓ You have the appropriate tools, lifting equipment and a suitable workshop.

The information contained in this Tech Tip is a supplement to the Service Manual. Consult the appropriate Service Manual of your machine for safety rules and hazards.



TECH TIP 57 | RELEASED 07.27.2022 | VERSION 1.0
©TEREX UTILITIES. ALL RIGHTS RESERVED

CONTENTS

TECH TIP #57

TOC

4

| Assess the boom position and identify any obstructions

INTRODUCTION
STEP 1

5

STEP 2

8

| Lower boom extension letdown

STEP 3 - STEP 4

9

| Upper boom letdown

STEP 5 - STEP 6

10

STEP 7

INTRODUCTION

7/8" wrench and jack handled on supplied on the unit.



STEP 1

Assess the boom position and identify any obstructions. Remember when using the manual letdown, the lowering of the upper boom, lower boom, and the lower boom extension are all done by gravity alone. None of the interlock systems will operate. The platform will not level as the booms are lowered. Plan the movements required to get the platform to the ground before using the manual letdown system.

MANUAL LET DOWN

The manual let down system works by gravity only. It can not raise a boom or level. Plan the movements required to get the platform to the ground. The let down system lowers only the Lower Boom, Upper Boom, Lower boom extension and will release the Rotation Brake to allow manual rotation.

OPERATION INSTRUCTIONS:

Only operate one function at a time.

1. Select the boom function desired for the sequence planned. Pull and twist the knob to lock in "OUT" position.
2. Use pump handle stored on control cover to pump up pressure, (about 2 strokes).
- Ⓐ Engage push button on valve, until the function begins to move or you can rotate the gearbox hex shaft.
3. Slowly meter with lower control lever in "down" direction to increase speed.
4. To stop movement of function move selector to "IN" position.
5. Repeat for the next function in planned sequence.
6. To rotate, turn knob "CW" and pump up (about 2 strokes) to release brake, then manually rotate with 7/8" wrench on rotation motor shaft.

Return all selectors to "IN" or "CCW" position for normal operation. After using the manual let down function cycle boom through full range of motion from the lower controls before operation from the platform.

Note: Platform leveling will not function when using manual let down. Boom movement will not stop until selector is in "IN" or "CCW" position.

480723



STEP 1 (Continued)

The unit can be rotated using a hex fitting on top of the rotation motor.

The manual letdown will not extend or retract the upper boom or the Jacks.

Only use one function at a time when using the manual letdown system.

Once the manual letdown system has been activated, all four of the letdown controls must be returned to neutral to stop the motion of the boom.



The platform will not level when using the manual letdown.

STEP 2

When the manual letdown is used, none of the safety limit systems are operational. Unless the unit needs to be rotated to clear obstacles, proceed to Step 3 to retract the lower boom.

If the platform or the boom is near any obstacles and needs to be rotated away before lowering the unit, rotate it by turning the far right knob to 3 o'clock. **Figure 3**



The safety limit systems are not operational when using the manual letdown.

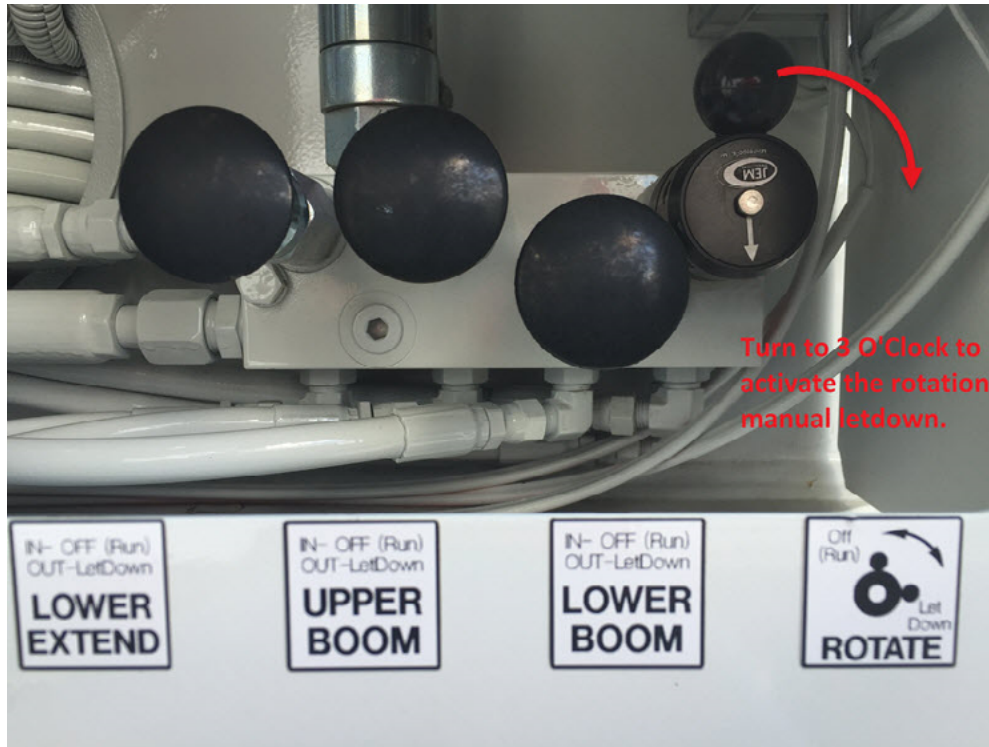

FIGURE 3

STEP 2 (Continued)

Using the jack handle, pump up the handle until it gets hard, (you may need to keep pumping the jack intermittently to keep brake released).

Push the counterbalance override on the brake valve and use the 7/8" wrench to rotate the unit. Figures 4 and 5



FIGURE 4

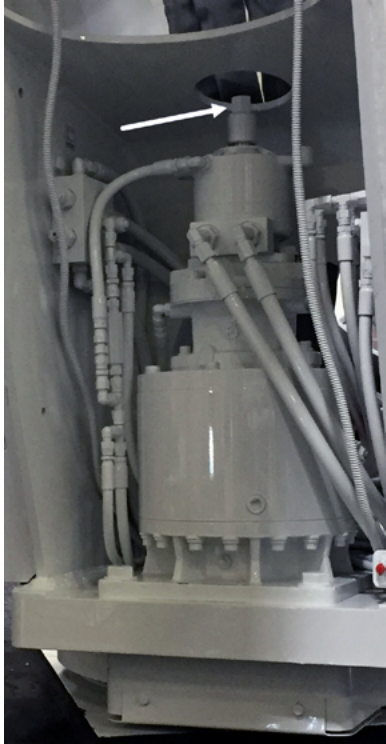

FIGURE 5

STEP 2 (Continued)

Rotation will be stopped when the manual override button is released. Turning the knob back to its original position will also stop rotation.

If the brake valve does not have the manual override button, a lot of force is needed to rotate. You can turn the counterbalance valves in clockwise to decrease the pressure and allow manual rotation.



The counterbalance valves must be reset before the unit is returned to service.

STEP 3

To activate the lower boom extension letdown, pull the first knob on the left side and then turn to lock it in position. Pump the handle until the boom starts to come down. Always retract the lower boom extension fully before lowering the lower boom.



The lower boom extension will retract quicker by moving the handle of the lower boom extension valve, allowing oil to go back to tank faster.

To stop the boom simply pull the manual letdown knob and turn back to the normal position. This will close the pilot valve stopping the movement.

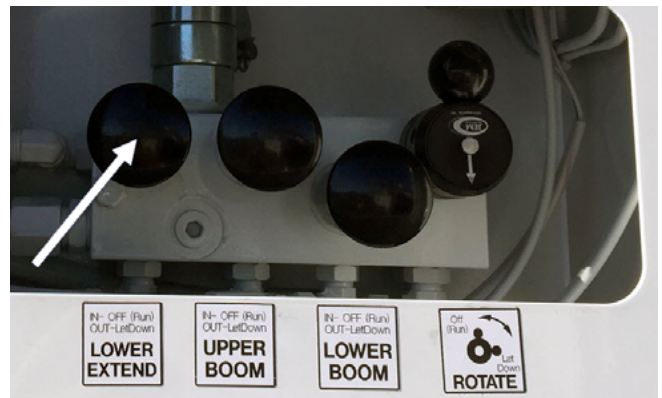

STEP 4

Depending on what position the upper and lower booms are in will determine which boom must be lowered next. Remember that the booms come down with GRAVITY only and none of the limit systems will work. This includes the over-center limit system. Do not allow the platform to go past the vertical center of rotation at any time.



The safety limit systems are not operational when using the manual letdown.



Do not allow the platform to go past the vertical center of rotation at any time.

STEP 5

To activate the upper boom letdown, pull the second knob from the left and lock it in the out position. When movement stops push it back in and pump the jack up again. Next pull the third knob from the left (lower boom) until movement stops. Keep repeating as necessary between the upper boom and lower boom functions. Only operate one function at a time.

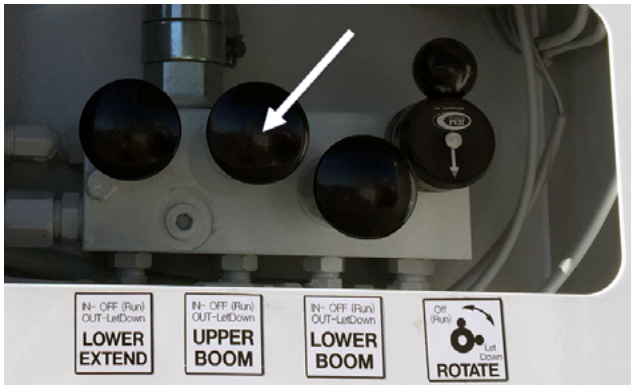

STEP 6

If the position of the upper and lower booms allows the lower boom to be lowered, first lower the lower boom making sure that the platform does not go past center of rotation. Then lower the upper boom. It may be necessary to keep pumping the manual letdown jack to maintain pressure to the pilot valves.

Lowering both booms individually back and forth will help prevent the platform from completely dumping upside down. If the upper boom is lowered first the platform could be completely upside down depending on the angle of the boom starting position.



The lower boom extension must be fully retracted before lowering the lower boom.



The safety limit systems are not operational when using the manual letdown.



Do not allow the platform to go past the vertical center of rotation at any time.



The platform will not level when using the manual letdown.



Only manually operate one function at a time.

STEP 7

Note: Remember to return all the letdown valves back to the “in position” for Lower, Upper Boom and Lower boom Extension. Turn the Rotation back to 12 o'clock for normal operation.

Before returning the unit to service and allowing anyone to operate the platform, the air that entered the cylinders while manually lowering the unit must be purged.



Any air that has entered the hydraulic system must be purged before the unit is placed back into service or anyone is allowed to operate the unit from the platform.

To remove the air, retract the upper boom, lower boom and lower boom extension cylinders before extending the cylinders through their full range of motion.

Cycle the lower boom lift no more than 45 degrees 3 times with the upper boom opened far enough to clear the body. Then cycle the lower boom fully.

With lower boom raised, extend the upper boom up and down and extend the lower boom cylinder out fully before retracting. Run the cylinder through the full range of movement twice.

The lower boom will not extend until it is above the minimum angle for the lower boom limit system.

- For TM125 models the lower boom needs to be above 70 degrees.
- On TM105, TM100, and TM85 models the lower boom needs to be above 55 degrees.



FOR FURTHER ASSISTANCE,
CONTACT THE TEREX UTILITIES TECHNICAL SUPPORT TEAM
PHONE: **1-844-TEREX4U (1-844-837-3948)** | EMAIL: **UTILITIES.SERVICE@TEREX.COM**
